

# BRASLUX



Catálogo 2026

# Revelando **Horizontes**

Fundada em 1976, a Braslux é uma empresa brasileira líder na fabricação de soluções de iluminação totalmente em LED para o setor automotivo pesado. Com cinco décadas de experiência, tem como propósito entregar soluções customizadas que gerem valor, construam relações de confiança e conectem pessoas e tecnologias. A linha de produtos inclui lanternas, faróis, peças técnicas e acessórios elétricos e eletrônicos, todos projetados com foco em eficiência energética e design moderno, refletindo as últimas tendências do setor de iluminação automotiva.

***Descubra como a Braslux está sempre revelando novos horizontes.***

## ***Revealing new horizons***

*Founded in 1976, Braslux is a Brazilian company and a leader in manufacturing LED lighting solutions for the heavy automotive sector. With five decades of experience, its mission is to deliver customized solutions that create value, build trust, and connect people and technologies. The product line includes tail lights, headlights, technical parts, and electrical and electronic accessories, all designed with a focus on energy efficiency and modern design, reflecting the latest trends in the automotive lighting industry.*

*Discover how Braslux is always revealing new horizons.*

## ***Revelando horizontes.***

*Fundada en 1976, Braslux es una empresa brasileña líder en la fabricación de soluciones de iluminación LED para el sector automotriz pesado. Con cinco décadas de experiencia, su propósito es ofrecer soluciones personalizadas que generen valor, construyan relaciones de confianza y conecten personas y tecnologías. La línea de productos incluye luces traseras, faros, piezas técnicas y accesorios eléctricos y electrónicos, todos diseñados con un enfoque en la eficiencia energética y un design moderno, reflejando las últimas tendencias del sector de iluminación automotriz.*

*Descubre cómo Braslux siempre está revelando nuevos horizontes.*



# A escolha das **montadoras**

Em qualquer veículo, a segurança é fundamental. Nossos produtos são projetados para oferecer a mais alta performance e qualidade, integrando um design moderno e atrativo, e com a confiabilidade de 50 anos de experiência no mercado brasileiro. Não é por acaso que a Braslux é a original, a escolha das montadoras.

Com um compromisso sólido com o segmento, adotamos as mais avançadas inovações para garantir que nossa produção atenda aos exigentes padrões do setor automotivo pesado. Cada item, desde a fase de projeto até a produção, passa por rigorosos testes de qualidade para assegurar sua excelência.

**Escolha você também a original, escolha BRASLUX.**

## **The choice of vehicle manufacturers**

*In any vehicle, safety is essential. Our products are designed to deliver the highest performance and quality, combining modern and attractive design with the reliability of 50 years of experience in the Brazilian market. It's no coincidence that Braslux is the original, the choice of vehicle manufacturers.*

*With a solid commitment to the industry, we embrace the most advanced innovations to ensure our production meets the demanding standards of the heavy automotive sector. Each product, from the design phase to manufacturing, undergoes rigorous quality testing to guarantee excellence.*

*Choose the original. Choose BRASLUX.*

## **La Elección de los fabricantes de vehículos**

*En cualquier vehículo, la seguridad es esencial. Nuestros productos están diseñados para ofrecer el máximo rendimiento y calidad, combinando un design moderno y atractivo con la confiabilidad de 50 años de experiencia en el mercado brasileño. No es casualidad que Braslux sea la original, la elección de los fabricantes de vehículos.*

*Con un firme compromiso con el sector, adoptamos las innovaciones más avanzadas para garantizar que nuestra producción cumpla con los exigentes estándares del sector automotriz pesado. Cada producto, desde la fase de diseño hasta la fabricación, pasa por rigurosas pruebas de calidad para asegurar su excelencia.*

*Elige tú también la original. Elige BRASLUX.*

# *Por dentro* **da tecnologia**

---

*Inside Technology | Por dentro de la tecnología*

## Iluminação Automotiva: **LED vs Lâmpadas Halógenas**

### **Qual a diferença?**

- **Tecnologia:** Lâmpadas halógenas usam um filamento aquecido para gerar luz, enquanto LEDs (diodos emissores de luz) usam semicondutores.

### **Por que escolher produtos de LED?**

- **Mais luz:** LEDs proporcionam uma iluminação muito mais intensa, melhorando a visibilidade.
- **Duram mais:** LEDs possuem uma vida útil muito maior.
- **Economizam energia:** Consomem menos energia, ajudando a economizar combustível.
- **Personalizáveis:** Oferecem várias opções de cor de luz e permitem flexibilidade de design.
- **Sustentáveis:** São mais amigáveis ao meio ambiente.

### **Eficiência de Iluminação | LED vs Lâmpadas Halógenas:**

- LEDs transformam maior quantidade de energia em luz do que em calor.
- Iluminam melhor e ajudam a economizar combustível.
- A eficiência do produto não está diretamente ligada à quantidade de LEDs, é possível ter uma maior eficiência com menor quantidade desses componentes.

## **Automotive Lighting: LED vs Halogen Lights**

### **What's the difference?**

- **Technology:** Halogen lamps use a heated filament to generate light, while LEDs (light-emitting diodes) use semiconductors.

### **Why choose LED products?**

- **Brighter light:** LEDs provide much more intense illumination, improving visibility.
- **Longer lifespan:** LEDs last significantly longer.
- **Energy efficient:** They consume less energy, helping to save fuel.
- **Customizable:** Offer various light color options and design flexibility.
- **Sustainable:** More environmentally friendly.

### **Lighting Efficiency | LED vs. Halogen lamps:**

- LEDs convert more energy into light rather than heat.
- They provide better illumination and help save fuel.
- Product efficiency is not directly related to the number of LEDs, greater efficiency can be achieved with fewer components.

## **Iluminación Automotriz: LED vs. Luces Halógenas**

### **¿Cuál es la diferencia?**

- **Tecnología:** Las Luces halógenas utilizan un filamento calentado para generar luz, mientras que los LED (diodos emissores de luz) utilizan semiconductores.

### **¿Por qué elegir productos LED?**

- **Más luz:** Los LED proporcionan una iluminación mucho más intensa, mejorando la visibilidad.
- **Mayor durabilidad:** Los LED tienen una vida útil mucho más larga. **Ahorran energía:** Consumen menos energía, lo que ayuda a ahorrar combustible.
- **Eficiencia energética:** Consumen menos energía, ayudando a ahorrar combustible.
- **Personalizables:** Ofrecen varias opciones de color de luz y flexibilidad en el diseño.
- **Sostenibles:** Son más amigables con el medio ambiente.

### **Eficiencia de Iluminación | LED vs. Luces Halógenas:**

- Los LED convierten más energía en luz que en calor.
- Ofrecen mejor iluminación y ayudan a ahorrar combustible.
- La eficiencia del producto no está directamente relacionada con la cantidad de LED — es posible lograr una mayor eficiencia con menos componentes.

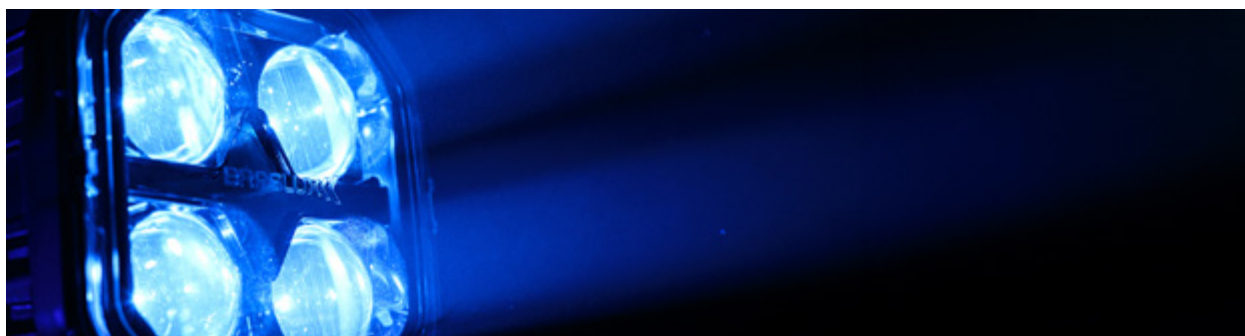

## Entendendo as unidades **de medidas de luz**

### **Lux ( $lm/m^2$ ):**

- Medida da quantidade de luz que chega a uma superfície. Mais lux significa maior quantidade de luz em um lugar específico.

### **Lúmen (lm):**

- Quantidade total de luz que uma fonte luminosa emite. Mais lúmens significa maior brilho.

### **Candela (cd):**

- Medida da intensidade da luz em uma única direção. Importante para o direcionamento focado da luz em faróis e lanternas.

### **Temperatura de Cor (Kelvin):**

- **Luz Azulada (Fria):** Temperaturas de cor mais altas.
- **Luz Amarelada (Quente):** Temperaturas de cor mais baixas.
- A escolha da cor afeta a visibilidade e o conforto ao dirigir.

### **Tipos de Iluminação:**

- **Spot:** Luz focada em um ponto.
- **Wide/Flood:** Luz espalhada para cobrir uma área maior.

## **Understanding Light Measurement Units**

### **Lux ( $lm/m^2$ ):**

- A measure of the amount of light hitting a surface. More lux means more light in a specific area.

### **Lumen (lm):**

- The total amount of light emitted by a light source. More lumens mean greater brightness.

### **Candela (cd):**

- A measure of light intensity in a single direction. Important for focused light projection in headlights and tail lights.

### **Color Temperature (Kelvin):**

- **Bluish (Cool) Light:** Higher color temperatures
- **Yellowish (Warm) Light:** Lower color temperatures.
- The choice of color affects visibility and driving comfort.

### **Types of Lighting:**

- **Spot:** Focused light on a single point.
- **Wide/Flood:** Diffused light covering a larger area.

## **Comprendiendo las Unidades de Medida de la Luz**

### **Lux ( $lm/m^2$ ):**

- Mide la cantidad de luz que llega a una superficie. Más lux significa más luz en un área específica.

### **Lumen (lm):**

- La cantidad total de luz emitida por una fuente luminosa. Más lúmenes significan mayor brillo.

### **Candela (cd):**

- Mide la intensidad de la luz en una dirección específica. Importante para la proyección focalizada de la luz en faros y luces traseras.

### **Color Temperature (Kelvin):**

- **Luz Azulada (Fría):** Temperaturas de color más altas.
- **Luz Amarillenta (Cálida):** Temperaturas de color más bajas.
- La elección del color afecta la visibilidad y la comodidad al conducir.

### **Tipos de Iluminación:**

- **Spot:** Luz enfocada en un punto.
- **Wide/Flood:** Luz esparcida para cubrir un área más grande.



## Testes Importantes **para Produtos**

### **Ensaio de Qualidade:**

- **Vibração:** Garante que os faróis resistam a estradas irregulares.
- **Salt Spray:** Testa resistência à corrosão, essencial em áreas úmidas ou salinas.
- **Proteção IP:** Verifica resistência a poeira e água.
- **Proteção UV:** Garante que os faróis resistam à luz solar intensa.
- **EMC:** Assegura que os faróis não causem interferências eletromagnéticas.
- **Fotométricos:** Medem a distribuição da luz para garantir a iluminação ideal.
- **Climáticos:** Testam resistência a temperaturas extremas.
- **Queda Livre:** Simula impactos para garantir durabilidade.
- **Resistência Química:** Verifica se os faróis resistem a produtos químicos como óleo e produtos de limpeza.

### **Important Tests for Products**

#### **Quality Tests:**

- **Vibration:** Ensures headlights withstand rough roads.
- **Salt Spray:** Tests corrosion resistance, essential for humid or salty environments.
- **IP Protection:** Checks resistance to dust and water.
- **UV Protection:** Ensures headlights endure intense sunlight.
- **EMC:** Confirms headlights do not cause electromagnetic interference.
- **Fotométricas:** Measures light distribution to guarantee optimal illumination.
- **Climatic:** Tests resistance to extreme temperatures.
- **Drop Test:** Simulates impacts to ensure durability.
- **Chemical Resistance:** Verifies headlights withstand exposure to chemicals like oil and cleaning products.

### **Pruebas Importantes para Productos**

#### **Ensayos de Calidad:**

- **Vibración:** Asegura que los faros resistan carreteras irregulares.
- **Salt Spray:** Prueba la resistencia a la corrosión, esencial en áreas húmedas o salinas.
- **Protección IP:** Verifica la resistencia al polvo y al agua.
- **Protección UV:** Garantiza que los faros soporten la luz solar intensa.
- **EMC:** Asegura que los faros no causen interferencias electromagnéticas.
- **Fotométricos:** Miden la distribución de la luz para garantizar una iluminación óptima.
- **Climáticos:** Prueban la resistencia a temperaturas extremas.
- **Prueba de Caída:** Simula impactos para asegurar la durabilidad.
- **Resistencia Química:** Verifica que los faros resistan productos químicos como aceites y productos de limpieza.



## Tipos de **Lentes e Refletores**

### **Lente Difusa:**

- Espalha a luz uniformemente com efeito HD, ideal para iluminar áreas mais amplas e próximas ao veículo.

### **Microóptica:**

- Direciona a luz com precisão, pode-se criar iluminação homogênea.

### **Fresnel:**

- Compacta e eficiente, usada para direcionar a luz sem aumentar o peso.

### **Colimadores:**

- Concentram a luz em um feixe estreito, ideal para visibilidade à longas distâncias.

### **Refletor Direto:**

- Reflete a luz diretamente, especialmente em faróis de longo alcance.

### **Refletor Indireto:**

- Redireciona a luz para áreas próximas, possibilita ocultar os LEDs.

### **Óptica Cristato:**

- Design inovador Braslux, ideal para lanternas modulares com alta visibilidade lateral.

## **Types of Lenses and Reflectors**

### **Diffused Lens:**

- Spreads light evenly with an HD effect, ideal for illuminating wider and closer areas around the vehicle.

### **Micro-optics:**

- Precisely directs light, allowing for uniform illumination.

### **Fresnel:**

- Compact and efficient, used to focus light without adding weight.

### **Collimators:**

- Concentrate light into a narrow beam, perfect for long-distance visibility.

### **Direct Reflector:**

- Reflects light straight ahead, especially for long-range headlights.

### **Indirect Reflector:**

- Redirects light to nearby areas, allowing LEDs to be hidden from view.

### **Cristato Optics:**

- An innovative Braslux design, ideal for modular tail lights with high lateral visibility.

## **Tipos de Lentes y Reflectores**

### **Lente Difusa:**

- Distribuye la luz uniformemente con un efecto HD, ideal para iluminar áreas más amplias y cercanas al vehículo.

### **Microóptica:**

- Dirige la luz con precisión, permitiendo una iluminación homogénea.

### **Lente Fresnel:**

- Compacta y eficiente, utilizada para enfocar la luz sin añadir peso.

### **Colimadores:**

- Concentran la luz en un haz estrecho, perfecto para la visibilidad a larga distancia.

### **Reflector Directo:**

- Refleja la luz directamente, especialmente en faros de largo alcance.

### **Reflector Indirecto:**

- Redirige la luz hacia áreas cercanas, permitiendo ocultar los LED.

### **Óptica Cristato:**

- Un design innovador de Braslux, ideal para luces traseras modulares con alta visibilidad lateral.



# Implementos Rodoviários

Applicable to Road Equipment | Aplicable en Implementos Viales



# Movimentação de Carga

Cargo handling | Movimiento de carga



# Ônibus

Buses | Autobuses

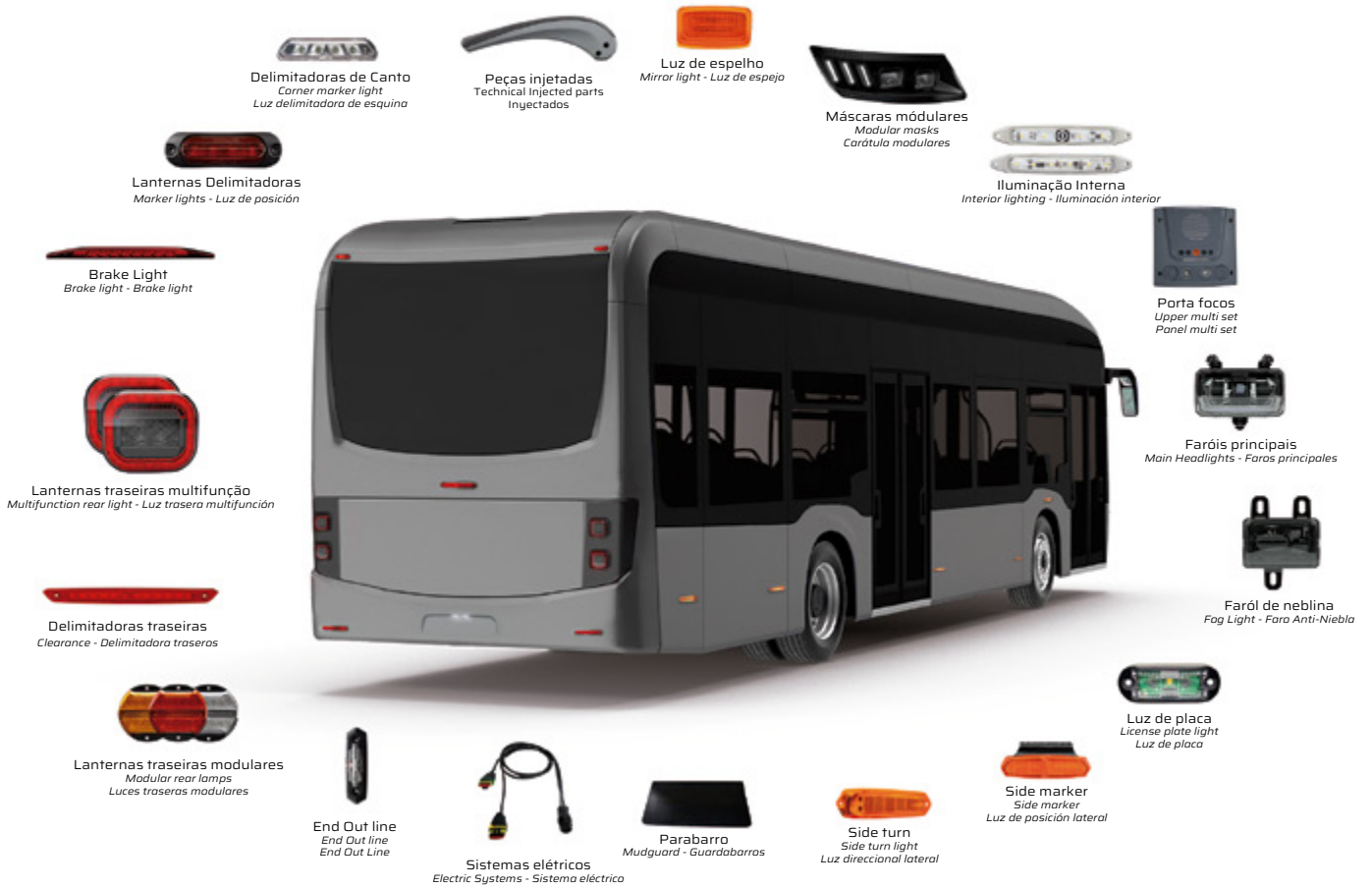

# Máquinas Agrícolas e de Construção

Agricultural and construction machines | Máquinas agrícolas y de construcción



# Sumário

Summary | Sumario

## 13 Lanternas Traseiras Multifunção

Multifunction Rear Lights  
Luces Traseras Multifunción

## 23 Lanternas Traseiras/Dianteiras Modulares

Modular Rear/Front Lights  
Luz Traseras/Delanteras Modulares

## 40 Lanternas Delimitadoras e Laterais

Marker and Side Lights  
Luz Delimitadoras y Laterales

## 61 Retrorrefletores

Retroreflectors  
Retrorreflectores

## 66 Iluminação Geral

General Lighting  
Iluminación General

## 73 Faróis

Headlights  
Faros

## 76 Faróis de Trabalho

Work Lights  
Faros de trabajo

## 80 Peças Técnicas

Technical Parts  
Piezas Técnicas

## 94 Acessórios Elétricos/Eletrônicos

Electrical/Electronic Accessories  
Accesorios Eléctricos/Electrónicos

# Legendas

Captions | Leyendas



### Ônibus

Buses  
Autobuses



### Implementos rodoviários

Applicable to Road Equipment  
Aplicable en Implementos Viales



### Máquinas agrícolas e de construção

Agricultural and construction machines  
Máquinas agrícolas y de construcción



### Movimentação de carga

Cargo handling  
Movimiento de carga



### Produto com LED

Product with LED  
Producto con LED



### Patenteado Braslux

Braslux Patented  
Patentado Braslux



### Atende Contran 970

Complies with Contran 970  
Cumple con Contran 970



### Atende ECE

Complies with ECE  
Cumple con ECE



### Atende DOT

Complies with DOT  
Cumple con DOT



### Atende EMC R10

Complies with EMC R10  
Cumple con EMC R10



### Grau de proteção IP6K7

Protection Rating IP6K7  
Grado de Protección IP6K7



### Grau de proteção IP6K9K

Protection Rating IP6K9K  
Grado de Protección IP6K9K

## Cores Color | Colores

Ambar

Ambar | Ambar

Rubi

Rubi | Rubi

Cristal

Crystal | Cristal

Verde

Green | Verde

Azul

Blue | Azul

Fumê

Smoke | Humo

# Lanternas traseiras multifunção

---

A mais alta tecnologia, durabilidade e eficiência que você só encontra nas lanternas originais Braslux.

## **Multifunction rear lights**

*Highest technology, durability and efficiency you found only in original Braslux lights.*

## **Luces traseras multifunción**

*La más alta tecnología, durabilidad y eficiencia que solo encuentras en las lanternas originales Braslux.*

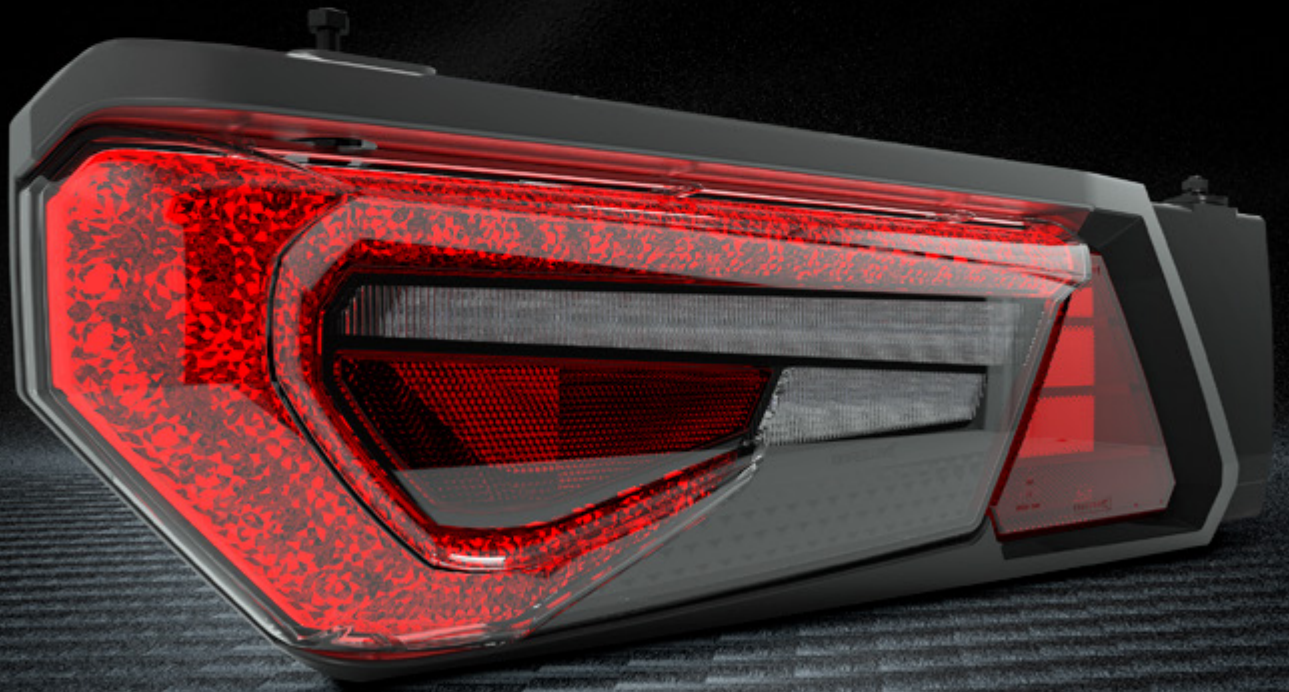



**8118 | Lanterna Volkan**  
Valkan Rear Light | Luz Trasera Volkan

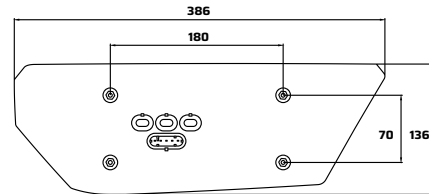

Direito <i>Right - Derecha</i>	Esquerdo <i>Left - Izquierda</i>	Tensão <i>Voltage - Voltaje</i>	Conexão <i>Connection - Conexión</i>	Fixação <i>Fixation - Fijación</i>	Funções <i>Functions - Funciones</i>	Observação <i>Observation - Observación</i>
8118.80.306	8118.81.306	12/24V	Selado 5 vias   Aux: 2 vias (posição)   2 vias (ré)   2 vias (flasher) <i>Sealed 5-Way Aux: 2-Way (Position)   2-Way (Reverse)   2-Way (Flasher)</i> Selado 5 Vias Aux: 2 Vias (Posição)   2 Vias (Reversa)   2 Vias (Flasher)	Traseira <i>Rear - Trasera</i>	Posição   Freio   Direcional   Retro <i>Position   Brake   Steering   Reverse</i> Posición   Freno   Direccional   Reversa	Com Prisioneiro <i>With Stud - Con Prisionero</i>

Original  
USICAMP, IBIPORA, FURGÕES JOINVILLE, SUL BRASIL



**8118 | Conjunto Lanterna Volkan**  
Valkan Rear Light Set | Conjunto de Luz Trasera Volkan

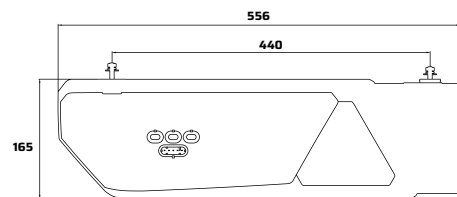

Direito <i>Right - Derecha</i>	Esquerdo <i>Left - Izquierda</i>	Tensão <i>Voltage - Voltaje</i>	Conexão <i>Connection - Conexión</i>	Fixação <i>Fixation - Fijación</i>	Funções <i>Functions - Funciones</i>	Observação <i>Observation - Observación</i>
8118.LD.000	8118.LE.000	12/24V	Selado 5 vias   Aux: 2 vias (posição)   2 vias (ré)   2 vias (flasher) <i>Sealed 5-Way Aux: 2-Way (Position)   2-Way (Reverse)   2-Way (Flasher)</i> Selado 5 Vias Aux: 2 Vias (Posição)   2 Vias (Reversa)   2 Vias (Flasher)	Superior <i>Top - Superior</i>	Posição   Freio   Direcional   Ré <i>Position   Brake   Steering   Reverse</i> Posición   Freno   Direccional   Reversa	
8118.LD.001	8118.LE.001			Traseira <i>Rear - Trasera</i>		

Original  
USICAMP, IBIPORA, FURGÕES JOINVILLE, SUL BRASIL



## 8110 | Lanterna Wings

Wings Rear Light | Luz Trasera Wings

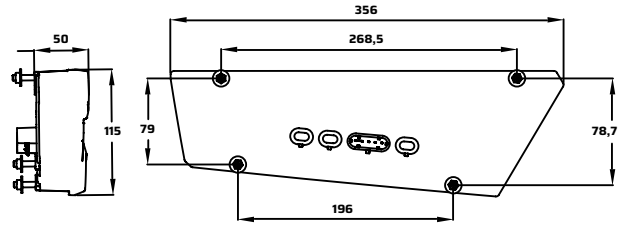

Direito <i>Right - Derecha</i>	Esquerdo <i>Left - Izquierda</i>	Tensão <i>Voltage - Voltaje</i>	Conexão <i>Connection - Conexión</i>	Fixação <i>Fixation - Fijación</i>	Funções <i>Functions - Funciones</i>	Observação <i>Observation - Observación</i>
8110.80.306	8110.81.306	12/24v	Selado 5 vias Aux: 2 vias (posição)   2 vias (ré)   2 vias (flasher)  <i>Sealed 5-Way Aux: 2-Way (Position)   2-Way (Reverse)   2-Way (Flasher)</i> <i>Sellado 5 Vias Aux: 2 Vias (Posición)   2 Vias (Reversa)   2 Vias (Flasher)</i>	Traseira <i>Rear - Trasera</i>	Posição   Freio   Direcional   Ré  <i>Position   Brake   Steering   Reverse</i> <i>Posición   Freno   Direccional   Reversa</i>	Sem Prisioneiro <i>Without Prisioner - Sin Prisionero</i>
8110.82.306	8110.83.306					Com Prisioneiro <i>With Prisioner - Con Prisionero</i>

Original  
Estrada



## 8110 | Conjunto Lanterna Wings

Wings Rear Light Set | Conjunto de Luz Trasera Wings

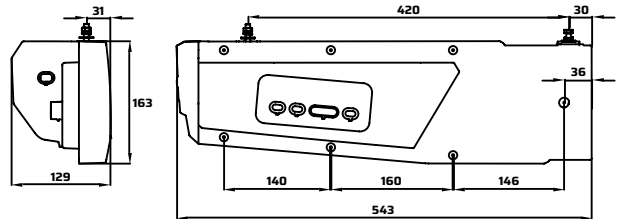

Direito <i>Right - Derecha</i>	Esquerdo <i>Left - Izquierda</i>	Tensão <i>Voltage - Voltaje</i>	Conexão <i>Connection - Conexión</i>	Fixação <i>Fixation - Fijación</i>	Funções <i>Functions - Funciones</i>	Observação <i>Observation - Observación</i>
8110.LD.000	8110.LE.000	12/24v	Selado 5 vias Aux: 2 vias (posição)   2 vias (ré)   2 vias (flasher)  <i>Sealed 5-Way Aux: 2-Way (Position)   2-Way (Reverse)   2-Way (Flasher)</i> <i>Sellado 5 Vias Aux: 2 Vias (Posición)   2 Vias (Reversa)   2 Vias (Flasher)</i>	Traseira <i>Rear - Trasera</i>	Posição   Freio   Direcional   Ré  <i>Position   Brake   Steering   Reverse</i> <i>Posición   Freno   Direccional   Reversa</i>	Com Complemento lateral <i>Left with side complement</i> <i>Izquierda con complemento lateral</i>
8110.LD.001	8110.LE.001					Sem Complemento lateral <i>Without side complement</i> <i>Sin complemento lateral</i>
8110.LD.004	8110.LE.004			Superior <i>Top - Superior</i>	Com Complemento lateral <i>Left with side complement</i> <i>Izquierda con complemento lateral</i>	

Original  
Estrada



## 8150 | Lanterna Gemini

Gemini Rear Light | Luz Trasera Gemini

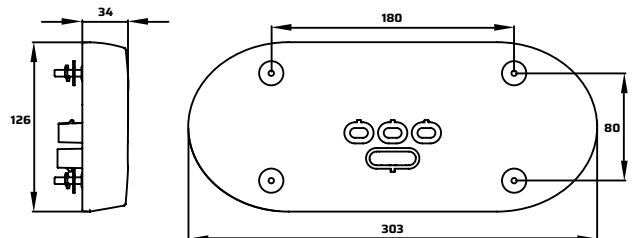

Código <i>Code - Código</i>	Tensão <i>Voltage - Voltaje</i>	Conexão <i>Connection - Conexión</i>	Fixação <i>Fixation - Fijación</i>	Funções <i>Functions - Funciones</i>	Observação <i>Observation - Observación</i>
8150.80.326	12/24v	Selado 5 vias Aux: 2 vias (posição)   2 vias (ré) <i>Sealed 5 Wires Aux: 2 Wires (Position)   2 Wires (Reverse)</i> <i>Sellado 5 Vias Aux: 2 Vias (Posición)   2 Vias (Reversa)</i>	Traseira <i>Rear - Trasera</i>	Posição   Freio   Direcional   Ré  <i>Position   Brake   Steering   Reverse</i> <i>Posición   Freno   Direccional   Reversa</i>	Sem Prisioneiro <i>Without Stud - Sin Prisionero</i>
8150.81.326					Com Prisioneiro <i>With Stud - Con Prisionero</i>

Original  
Nostra, Mauro Toia



## 8150 | Conjunto Lanterna Gemini

Gemini Rear Light Set | Conjunto de Luz Traseira Gemini

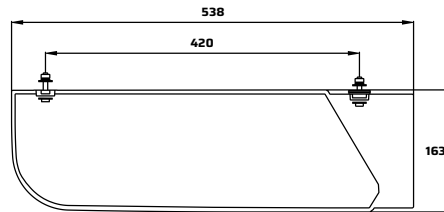

Direito <i>Right - Derecha</i>	Esquerdo <i>Left - Izquierda</i>	Tensão <i>Voltage - Voltaje</i>	Conexão <i>Connection - Conexión</i>	Fixação <i>Fixation - Fijación</i>	Funções <i>Functions - Funciones</i>	Observação <i>Observation - Observación</i>
8150.LD.000	8150.LE.000	12/24v	Selado 5 vias Aux: 2 vias (posição) 2 vias (ré)  <i>Sealed 5-Way Aux: 2-Way (Position) 2-Way (Reverse) Sellado 5 Vías Aux: 2 Vías (Posición) 2 Vías (Reversa)</i>	Superior <i>Top - Superior</i>	Posição   Freio   Direcional   Retro <i>Position   Brake   Steering   Reverse Posición   Freno   Direccional   Reversa</i>	-

Original  
Nostra, Mauro Toia



## 8934 | Lanterna Diamond IV

Diamond IV Rear Light | Luz Traseira Diamond IV

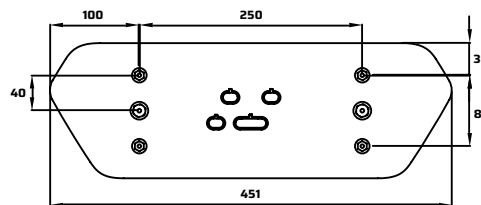
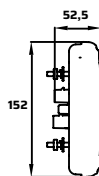

Direito <i>Right - Derecha</i>	Esquerdo <i>Left - Izquierda</i>	Tensão <i>Voltage - Voltaje</i>	Conexão <i>Connection - Conexión</i>	Fixação <i>Fixation - Fijación</i>	Funções <i>Functions - Funciones</i>	Observação <i>Observation - Observación</i>
8934.LD.005	8934.LE.005	24v	Selado 5 vias Aux: 2 vias (posição) 2 vias (ré)   2 vias (flasher)  <i>Sealed 5-Way Aux: 2-Way (Position) 2-Way (Reverse) 2-Way (Flasher) Sellado 5 Vías Aux: 2 Vías (Posición) 2 Vías (Reversa) 2 Vías (Flasher)</i>	Traseira <i>Rear - Trasera</i>	Posição   Freio   Direcional   Retro <i>Position   Brake   Steering   Reverse Posición   Freno   Direccional   Reversa</i>	Com Prisioneiro <i>With Stud - Con Prisionero</i>

Original  
GUERRA



## 8934 | Lanterna Diamond III

Diamond III Rear Light | Luz Traseira Diamond III

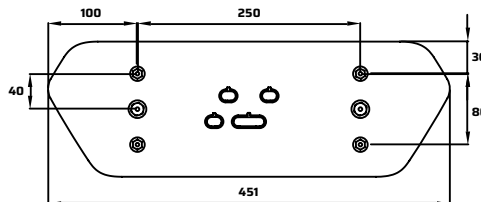
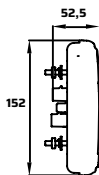

Direito <i>Right - Derecha</i>	Esquerdo <i>Left - Izquierda</i>	Tensão <i>Voltage - Voltaje</i>	Conexão <i>Connection - Conexión</i>	Fixação <i>Fixation - Fijación</i>	Funções <i>Functions - Funciones</i>	Observação <i>Observation - Observación</i>
8934.LD.004	8934.LE.004	24v	Selado 5 vias Aux: 2 vias (posição) 2 vias (ré)  <i>Sealed 5-Way Aux: 2-Way (Position) 2-Way (Reverse) Sellado 5 Vías Aux: 2 Vías (Posición) 2 Vías (Reversa)</i>	Traseira <i>Rear - Trasera</i>	Posição   Freio   Direcional   Retro <i>Position   Brake   Steering   Reverse Posición   Freno   Direccional   Reversa</i>	Com Prisioneiro <i>With Stud - Con Prisionero</i>

Original  
GUERRA



## 8930 | Lanterna Diamond II

Diamond II Rear Light | Luz Trasera Diamond II

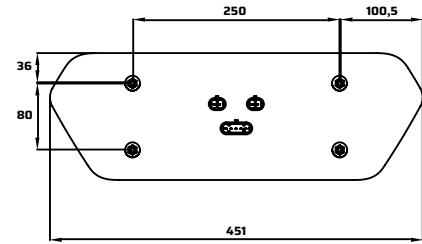
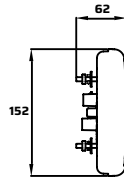

Direito <i>Right - Derecha</i>	Esquerdo <i>Left - Izquierda</i>	Tensão <i>Voltage - Voltaje</i>	Conexão <i>Connection - Conexión</i>	Fixação <i>Fixation - Fijación</i>	Funções <i>Functions - Funciones</i>	Observação <i>Observation - Observación</i>
8930.LD.201	8930.LE.201	12/24v	Selado 5 vias Aux: 2 vias (posição) 2 vias (ré)  <i>Sealed 5-Way Aux: 2-Way (Position) 2-Way (Reverse) Sellado 5 Vias Aux: 2 Vias (Posición) 2 Vias (Reversa)</i>	Traseira <i>Rear - Trasera</i>	Posição   Freio   Direcional   Retro <i>Position   Brake   Steering   Reverse Posición   Freno   Direccional   Reversa</i>	Com Prisioneiro <i>With Stud - Con Prisionero</i>

Original  
GUERRA



## 8541 | Lanterna Style III

Style III Rear Light | Luz Trasera Style III

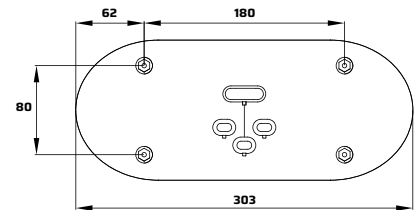
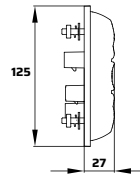

Código <i>Code - Código</i>	Tensão <i>Voltage - Voltaje</i>	Conexão <i>Connection - Conexión</i>	Fixação <i>Fixation - Fijación</i>	Funções <i>Functions - Funciones</i>	Observação <i>Observation - Observación</i>
8541.80.325	12/24v	Selado 5 vias Aux: 2 vias (posição) 2 vias (ré)  <i>Sealed 5-Way Aux: 2-Way (Position) 2-Way (Reverse) Sellado 5 Vias Aux: 2 Vias (Posición) 2 Vias (Reversa)</i>	Traseira <i>Rear - Trasera</i>	Posição   Freio   Direcional   Retro <i>Position   Brake   Steering   Reverse Posición   Freno   Direccional   Reversa</i>	Branco <i>White - Blanco</i>
8541.82.325					Metalizado <i>Metallic - Metalizado</i>

Original  
RANDON



## 8593 | Lanterna E6

E6 Rear Light | Luz Trasera E6

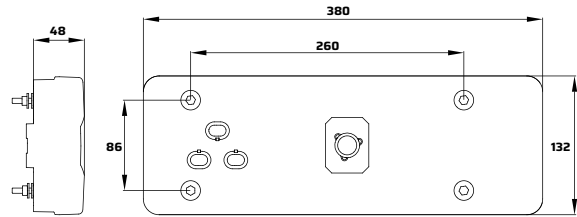

Direito <i>Right - Derecha</i>	Esquerdo <i>Left - Izquierda</i>	Tensão <i>Voltage - Voltaje</i>	Conexão <i>Connection - Conexión</i>	Fixação <i>Fixation - Fijación</i>	Funções <i>Funcions - Funciones</i>	Observação <i>Observation - Observación</i>
8593.80.325	8593.81.325	12/24v	Roscado 7 vias Aux: 2 vias (posição)   2 vias (ré) <i>Threaded 7 Wires Aux: 2 Wires (Position)   2 Wires (Reverse)</i> <i>Rosca 7 Vias Aux: 2 Vias (Posición)   2 Vias (Reversa)</i>	Traseira <i>Rear - Trasera</i>	Posição   Freio   Direcional   Retro <i>Position   Brake   Steering   Reverse</i> <i>Posición   Freno   Direccional   Reversa</i>	Com Prisioneiro <i>With Stud - Con Prisionero</i>

Original  
Rossetti



## 8074 | Lanterna Duct Wide

Duct Wide Rear Light | Luz Trasera Duct Wide

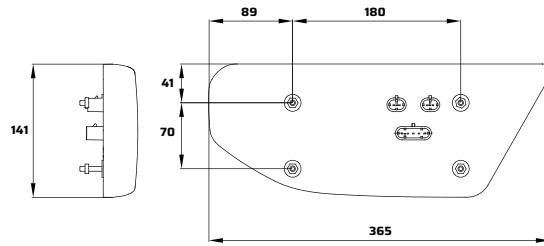

Direito <i>Right - Derecha</i>	Esquerdo <i>Left - Izquierda</i>	Tensão <i>Voltage - Voltaje</i>	Conexão <i>Connection - Conexión</i>	Fixação <i>Fixation - Fijación</i>	Funções <i>Funcions - Funciones</i>	Observação <i>Observation - Observación</i>
8074.80.325	8074.81.325	12/24v	Selado 5 vias Aux: 2 vias (posição) 2 vias (ré)	Traseira <i>Rear - Trasera</i>	Posição   Freio   Direcional   Retro <i>Position   Brake   Steering   Reverse</i> <i>Posición   Freno   Direccional   Reversa</i>	Sem prisioneiro <i>Without Stud - Sin Prisionero</i>
8074.82.325	8074.83.325		Selada 5-Way Aux: 2-Way (Position) 2-Way (Reverse) <i>Sellado 5 Vias Aux: 2 Vias (Posición) 2 Vias (Reversa)</i>			Com prisioneiro <i>With Stud - Con Prisionero</i>

Original  
GOTTI, ENOVA, STARA, METALESP



## 8074 | Conjunto Lanterna Duct Wide

Duck Wide Rear Light Set | Conjunto de Lanterna Duct Wide

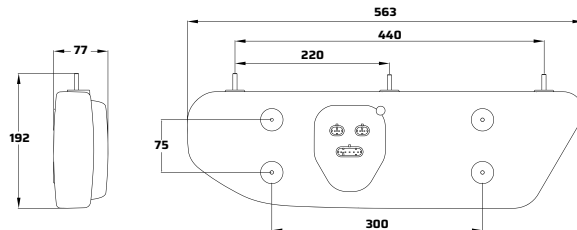

Direito <i>Right - Derecha</i>	Esquerdo <i>Left - Izquierda</i>	Tensão <i>Voltage - Voltaje</i>	Conexão <i>Connection - Conexión</i>	Fixação <i>Fixation - Fijación</i>	Funções <i>Funcions - Funciones</i>	Observação <i>Observation - Observación</i>
8074.LD.100	8074.LE.100	12/24v	Selado 5 vias Aux: 2 vias (posição) 2 vias (ré) <i>Selada 5-Way Aux: 2-Way (Position) 2-Way (Reverse)</i> <i>Sellado 5 Vias Aux: 2 Vias (Posición) 2 Vias (Reversa)</i>	Superior <i>Top - Superior</i>	Posição   Freio   Direcional   Ré <i>Position   Brake   Steering   Reverse</i> <i>Posición   Freno   Direccional   Reversa</i>	Sem complemento lateral <i>Without Lateral Attachment</i> <i>Sin Complemento Lateral</i>
8074.LD.101	8074.LE.101			Traseira <i>Rear - Trasera</i>		Com complemento lateral <i>With Lateral Attachment</i> <i>Con Complemento Lateral</i>
8074.LD.102	8074.LE.102					Sem complemento lateral <i>Without Lateral Attachment</i> <i>Sin Complemento Lateral</i>
8074.LD.104	8074.LE.104					Com complemento lateral <i>With Lateral Attachment</i> <i>Con Complemento Lateral</i>

Original  
GOTTI, ENOVA



## 8518 | Lanterna Flex II

Flex II Rear Light | Luz Trasera Flex II

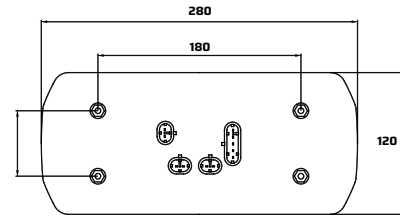
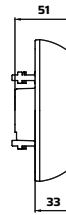

Código <i>Code - Código</i>	Tensão <i>Voltage - Voltaje</i>	Conexão <i>Connection - Conexión</i>	Fixação <i>Fixation - Fijación</i>	Funções <i>Functions - Funciones</i>	Observação <i>Observation - Observación</i>
8518.85.325	12/24v	Selado 5 vias Aux: 2 vias (posição) 2 vias (ré)	Traseira <i>Rear - Trasera</i>	Posição   Freio   Ré Direcional <i>Position   Brake   Reverse   Steering</i> <i>Posición   Freno   Reversa   Direccional</i>	Sem Prisioneiro <i>Without Stud - Sin Prisionero</i>
8518.86.325		Sealed 5-Way Aux: 2-Way (Position) 2-Way (Reverse) Sellado 5 Vias Aux: 2 Vias (Posición) 2 Vias (Reversa)			Com Prisioneiro <i>With Stud - Con Prisionero</i>

Original  
IBIPORÁ, GRIMALDI



## 8518 | Conjunto Lanterna Flex II

Flex II Rear Light Set | Conjunto de Lanterna Flex II

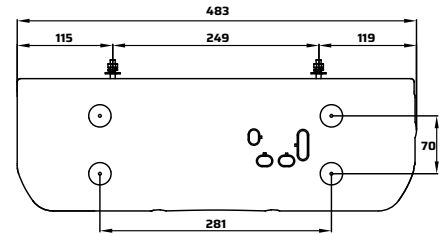
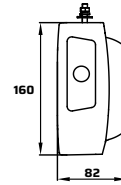

Direito <i>Right - Derecha</i>	Esquerdo <i>Left - Izquierda</i>	Tensão <i>Voltage - Voltaje</i>	Conexão <i>Connection - Conexión</i>	Fixação <i>Fixation - Fijación</i>	Funções <i>Functions - Funciones</i>	Observação <i>Observation - Observación</i>
8518.LD.102	8518.LE.102	12/24v	Selado 5 vias Aux: 2 vias (posição) 2 vias (ré)  Sealed 5-Way Aux: 2-Way (Position) 2-Way (Reverse) Sellado 5 Vias Aux: 2 Vias (Posición) 2 Vias (Reversa)	Superior <i>Top - Superior</i>	Posição   Freio   Retro Direcional <i>Position   Brake   Reverse   Steering</i> <i>Posición   Freno   Reversa   Direccional</i>	-
8518.LD.103	8518.LE.103			Traseira <i>Rear - Trasera</i>		

Original  
IBIPORA



## 8517 | Conjunto Lanterna Duo II

Duo II Rear Light Set | Conjunto de Lanterna Duo II

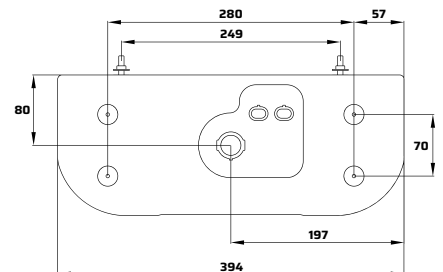
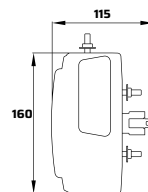

Direito <i>Right - Derecha</i>	Esquerdo <i>Left - Izquierda</i>	Tensão <i>Voltage - Voltaje</i>	Conexão <i>Connection - Conexión</i>	Fixação <i>Fixation - Fijación</i>	Funções <i>Functions - Funciones</i>	Observação <i>Observation - Observación</i>
8517.LD.102	8517.LE.102	24v	Roscado 7 vias <i>7-Way Threaded - Rosca de 7 Vias</i>	Superior <i>Top - Superior</i>	Posição   Freio   Ré Direcional <i>Position   Brake   Reverse   Steering</i> <i>Posición   Freno   Reversa   Direccional</i>	-



## 8056 | Conjunto Ø 155mm

Ø 155mm Rear Light Set | Conjunto Luz Trasera Ø 155mm

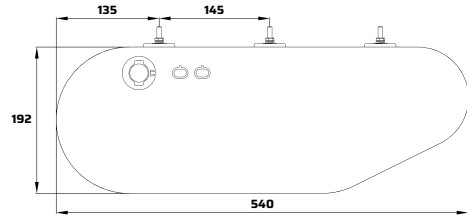

Direito <i>Right - Derecha</i>	Esquerdo <i>Left - Izquierda</i>	Tensão <i>Voltage - Voltaje</i>	Conexão <i>Connection - Conexión</i>	Fixação <i>Fixation - Fijación</i>	Funções <i>Functions - Funciones</i>	Observação <i>Observation - Observación</i>
8056.LD.200	8056.LE.200	24v	Roscado 7 vias <i>7 Way Threaded - Roscada de 7 Vías</i>	Superior <i>Top - Superior</i>	Posição   Freio   Direcional   Ré   Retro <i>Position   Brake   Steering   Reverse   Retro</i> Posición   Freno   Direccional   Reversa   Retro	-

Original  
NDMA



## 8052 | Conjunto Lanterna Trailer II

Trailer II Rear Light Set | Conjunto de Lanterna Trailer II

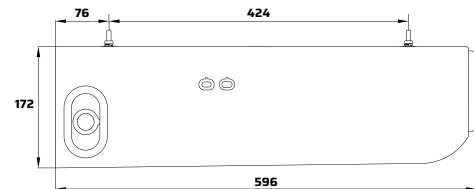

Direito <i>Right - Derecha</i>	Esquerdo <i>Left - Izquierda</i>	Tensão <i>Voltage - Voltaje</i>	Conexão <i>Connection - Conexión</i>	Fixação <i>Fixation - Fijación</i>	Funções <i>Functions - Funciones</i>	Observação <i>Observation - Observación</i>
8052.LD.000	8052.LE.000	24v	Roscado 7 vias <i>7 Way Threaded - Roscada de 7 Vías</i>	Superior <i>Top - Superior</i>	Posição   Freio   Direcional   Ré   Retro <i>Position   Brake   Steering   Reverse   Retro</i> Posición   Freno   Direccional   Reversa   Retro	-

Original  
LIBRELATO



## 8052 | Conjunto Lanterna Trailer III

Trailer III Rear Light Set | Conjunto de Lanterna Trailer III

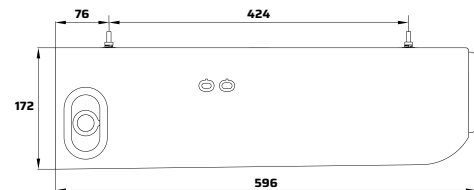

Direito <i>Right - Derecha</i>	Esquerdo <i>Left - Izquierda</i>	Tensão <i>Voltage - Voltaje</i>	Conexão <i>Connection - Conexión</i>	Fixação <i>Fixation - Fijación</i>	Funções <i>Functions - Funciones</i>	Observação <i>Observation - Observación</i>
8052.LD.200	8052.LE.200	24v	Roscado 7 vias <i>7 Way Threaded - Roscada de 7 Vías</i>	Superior <i>Top - Superior</i>	Posição   Freio   Direcional   Ré   Retro <i>Position   Brake   Steering   Reverse   Retro</i> Posición   Freno   Direccional   Reversa   Retro	-

Original  
LIBRELATO



## 8108 | Lanterna Teros

Teros Rear Light | Luz Trasera Teros

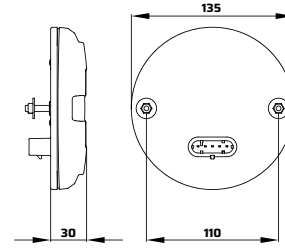

Código <i>Code - Código</i>	Tensão <i>Voltage - Voltaje</i>	Conexão <i>Connection - Conexión</i>	Fixação <i>Fixation - Fijación</i>	Funções <i>Functions - Funciones</i>	Observação <i>Observation - Observación</i>
8108.80.325	12/24v	Selada 5 Vias <i>Sealed 5 Pin - Sellados de 5 Vias</i>	Traseira <i>Rear - Trasera</i>	Posição   Freio   Direcional   Ré <i>Position   Brake   Steering   Reverse</i> <i>Posición   Freno   Direccional   Revers</i>	-
8108.81.325		Selada 4 Vias <i>Sealed 4 Pin - Sellados de 4 Vias</i>		Posição   Freio   Ré <i>Position   Brake   Reverse</i> <i>Posición   Freno   Revers</i>	
8108.82.325		Posição   Freio   Direcional <i>Position   Brake   Steering</i> <i>Posición   Freno   Direccional</i>			



## 8561 | Lanterna Multifunção

Multifunction Light | Luz Multifunción

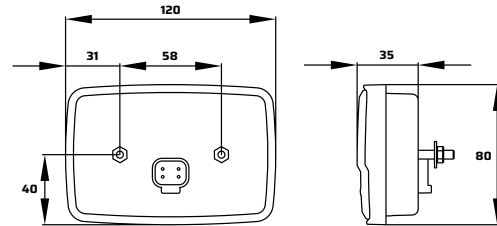

Código <i>Code - Código</i>	Tensão <i>Voltage - Voltaje</i>	Conexão <i>Connection - Conexión</i>	Fixação <i>Fixation - Fijación</i>	Funções <i>Functions - Funciones</i>	Observação <i>Observation - Observación</i>
8561.60.315	12V	Deutsch 4 Vias <i>4 Way Deutsch - Deutsch de 4 Vias</i>	Traseira <i>Rear - Trasera</i>	Posição   Direcional <i>Position   Steering - Posición   Direccional</i>	Sem luz de placa <i>Without License Plate Light</i> <i>Sin Luz de Placa</i>
8561.60.325				Posição   Freio   Direcional <i>Position   Brake   Steering</i> <i>Posición   Freno   Direccional</i>	Com luz de placa <i>With License Plate Light</i> <i>Con Luz de Placa</i>



## 8520 | Lanterna MF II

MF II Rear Light | Luz Trasera MF II

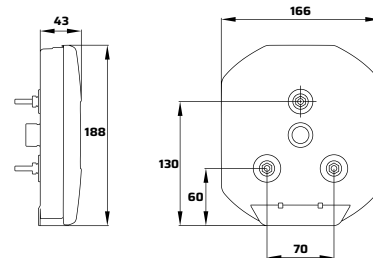

Código <i>Code - Código</i>	Tensão <i>Voltage - Voltaje</i>	Conexão <i>Connection - Conexión</i>	Fixação <i>Fixation - Fijación</i>	Funções <i>Functions - Funciones</i>	Observação <i>Observation - Observación</i>
8520.82.325	12/24v	Roscada 7 vias <i>7 Way Threaded - Roscado de 7 Vias</i>	Traseira <i>Rear - Trasera</i>	Posição   Freio   Direcional   Retro <i>Position   Brake   Steering   Reverse</i> <i>Posición   Freno   Direccional   Revers</i>	Sem luz de placa <i>Without License Plate Light</i> <i>Sin Luz de Placa</i>
8520.83.325				Com luz de placa <i>With License Plate Light</i> <i>Con Luz de Placa</i>	



Original  
GRIMALDI, TRUCKVAN

## 8548 | Lanterna MF Compacta

MF Compact Rear Light | Luz Trasera MF Compacta

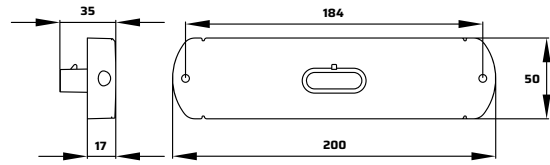
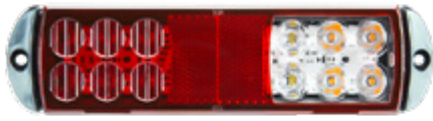

Código <i>Code - Código</i>	Tensão <i>Voltage - Voltaje</i>	Conexão <i>Connection - Conexión</i>	Fixação <i>Fixation - Fijación</i>	Funções <i>Functions - Funciones</i>	Observação <i>Observation - Observación</i>
8548.64.325	12V	Selado 5 Vias <i>Sealed 5 Pin - Sellados de 5 Vias</i>	Frontal <i>Frontal - Frontal</i>	Posição   Freio   Ré   Direcional   Retro <i>Position   Brake   Reverse   Steering Posición   Freno   Reversa   Direccional</i>	-
8548.65.325				Posição   Freio   Direcional   Retro <i>Position   Brake   Steering Posición   Freno   Direccional</i>	
8548.74.325	24V			Posição   Freio   Ré   Direcional   Retro <i>Position   Brake   Reverse   Steering Posición   Freno   Reversa   Direccional</i>	



# Lanternas traseiras e dianteiras modulares

---

Compactas e versáteis, com modelos de 1 até 4 funções, possibilitam flexibilidade de design para aplicações diversas.

## **Modular rear/front lights**

*Compact and versatile, with models with 1 to 4 functions, it enables design flexibility for various applications.*

## **Luces traseras/delanteras modulares**

*Compactas y versátiles, con modelos de 1 a 4 funciones, posibilitan flexibilidad de diseño para diversas aplicaciones.*

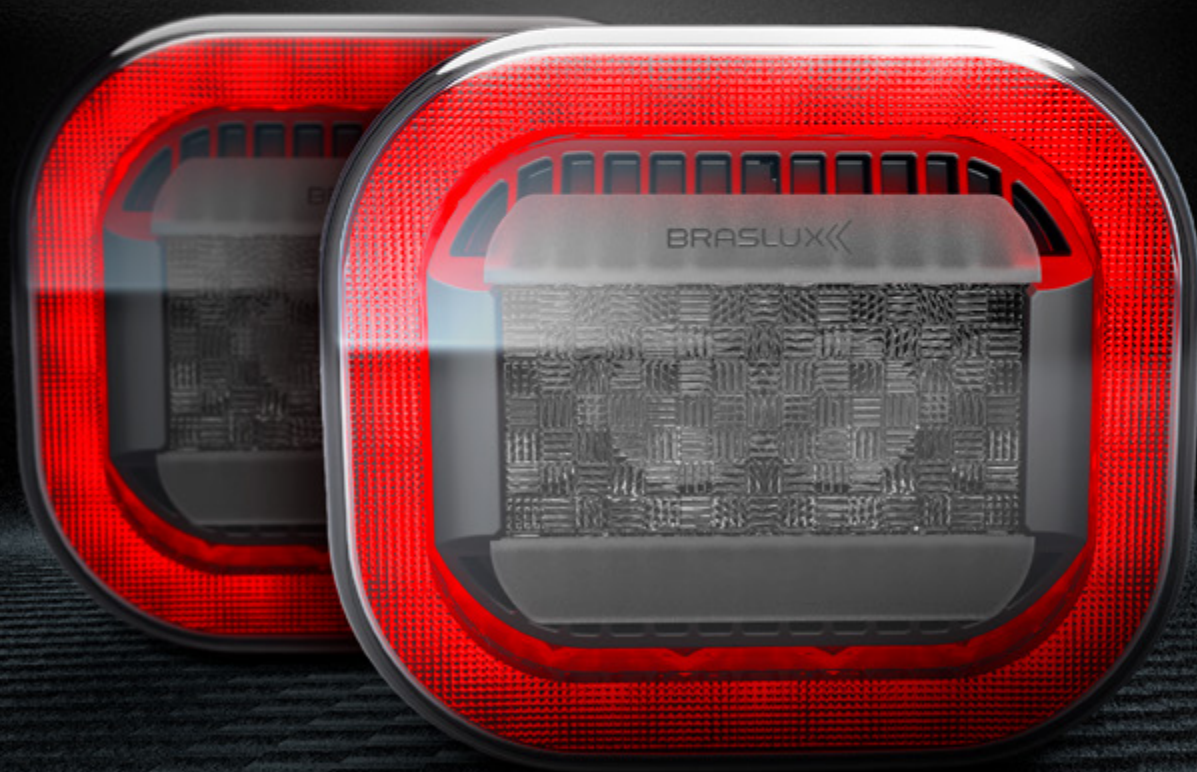

## 8133 | Lanterna Modular Sygna L

Modular Flashlight Sygna L | Linterna Modulare Sygna L

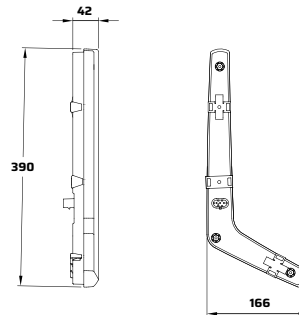

Lado A <small>Side A - Lado A</small>	Lado B <small>Side B - Lado B</small>	Tensão <small>Voltage - Voltaje</small>	Conexão <small>Connection - Conexión</small>	Fixação <small>Fixation - Fijación</small>	Funções <small>Functions - Funciones</small>
■ 8133.80.302	8133.82.302	12/24V	Superseal 3 vias	Traseira <small>Rear - Trasera</small>	Posição   Freio <small>Position   Steering - Posición   Direccional</small>
■ 8133.81.302	8133.83.302			Traseira Clip <small>Clip Rear - Trasera Clip</small>	



## 8132 | Lanternas Modulares Sygna M

Modular Flashlight Sygna M | Linternas Modulares Sygna M

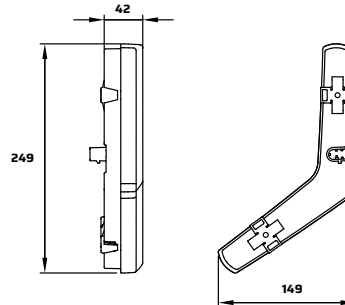

Lado A <small>Side A - Lado A</small>	Lado B <small>Side B - Lado B</small>	Tensão <small>Voltage - Voltaje</small>	Conexão <small>Connection - Conexión</small>	Fixação <small>Fixation - Fijación</small>	Funções <small>Functions - Funciones</small>
■ 8132.80.302		12/24V	Superseal 3 vias	Traseira M5 <small>M5 Rear - Trasera M5</small>	Posição <small>Position - Posición</small>
■ 8132.81.302				Traseira Clip <small>Clip Rear - Trasera Clip</small>	
□ 8132.80.306				Traseira M5 <small>M5 Rear - Trasera M5</small>	Direccional <small>Turn Sygna - Direccional</small>
□ 8132.81.306				Traseira Clip <small>Clip Rear - Trasera Clip</small>	Posição   Freio <small>Position   Steering - Posición   Direccional</small>
■ 8132.82.302	8132.80.302	24V			



## 8131 | Lanterna Modular Sygna S

Modular Flashlight Sygna S | Linterna Modular Sygna S

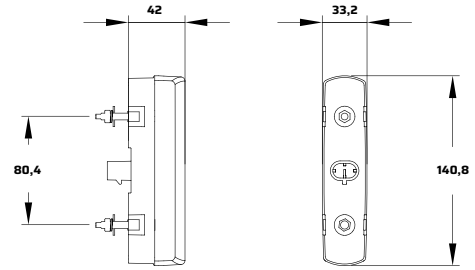

Código <i>Code - Código</i>	Tensão <i>Voltage - Voltaje</i>	Conexão <i>Connection - Conexión</i>	Fixação <i>Fixation - Fijación</i>	Funções <i>Functions - Funciones</i>	Observação <i>Observation - Observación</i>
■ 8131.80.302	12/24V	Superseal 2 vias	Traseira M5 <i>M5 Rear - Traseira M5</i>	Posição <i>Position - Posición</i>	
■ 8131.81.302			Traseira Clip <i>Clip Rear - Traseira Clip</i>		
□ 8131.80.308			Traseira M5 <i>M5 Rear - Traseira M5</i>	Direcional <i>Turn Sygna - Direccional</i>	
□ 8131.81.306			Traseira Clip <i>Clip Rear - Traseira Clip</i>		
□ 8131.82.306			Traseira M5 <i>M5 Rear - Traseira M5</i>	Ré <i>Reverse - Reversa</i>	
□ 8131.83.306			Traseira Clip <i>Clip Rear - Traseira Clip</i>		
■ 8131.82.302			Traseira M5 <i>M5 Rear - Traseira M5</i>	Freio <i>Reverse - Reversa</i>	
■ 8131.83.302			Traseira Clip <i>Clip Rear - Traseira Clip</i>		
■ 8131.84.302			Traseira M5 <i>M5 Rear - Traseira M5</i>	Neblina <i>Fog - Niebla</i>	
■ 8131.85.302			Traseira Clip <i>Clip Rear - Traseira Clip</i>		



## 8124 | Lanterna Ultraline

Ultraline Light - Linterna Ultraline

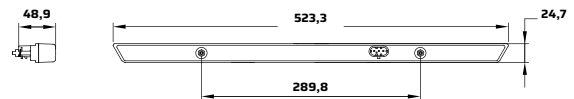

Lado A <i>Side A - Lado A</i>	Lado B <i>Side B - Lado B</i>	Tensão <i>Voltage - Voltaje</i>	Conexão <i>Connection - Conexión</i>	Fixação <i>Fixation - Fijación</i>	Funções <i>Functions - Funciones</i>
■ 8124.81.302	8124.82.302	12/24V	Superseal 3 vias	Traseira M5 <i>M5 Rear - Traseira M5</i>	Posição <i>Position - Posición</i>
■ 8124.81.302	8124.82.302				



## 8117 | Lanterna DRL Axis

Axis DRL Light | Luz DRL Axis

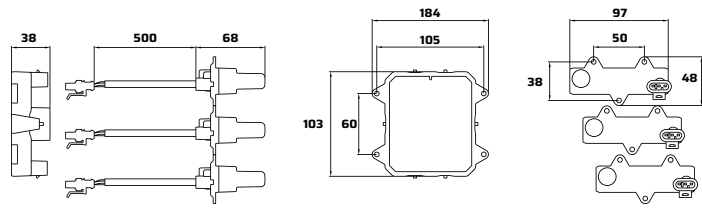

Código <small>Code - Código</small>	Tensão <small>Voltage - Voltaje</small>	Conexão <small>Connection - Conexión</small>	Fixação <small>Fixation - Fijación</small>	Funções <small>Functions - Funciones</small>	Observação <small>Observation - Observación</small>
8117.80.305	12/24V	Selado 4 Vias 4-Pin Sealed - Sellado de 4 Vias	Frontal Front - Frontal	Posição   Direcional   DRL Position   Directional   DRL Posición   Direccional   DRL	Com 3 Módulos With 3 Modules - Con 3 Módulos
8117.81.305					Com 4 Módulos With 4 Modules - Con 4 Módulos
8117.82.305					Sequencial com 3 Módulos Sequential with 3 Modules Secuencial con 3 Módulos
8117.83.305					Sequencial com 4 Módulos Sequential with 4 Modules Secuencial con 4 Módulos



## 8119 | Lanterna Allure

Allure Light | Luz Allure

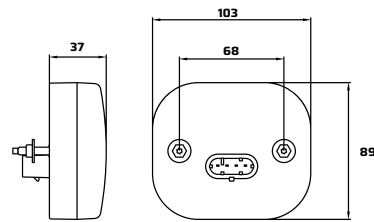

Código <small>Code - Código</small>	Tensão <small>Voltage - Voltaje</small>	Conexão <small>Connection - Conexión</small>	Fixação <small>Fixation - Fijación</small>	Funções <small>Functions - Funciones</small>	Observação <small>Observation - Observación</small>
8119.82.306	12/24V	Selado 4 Vias 4 Pin Sealed - Sellado de 4 Vias	Traseira Rear - Trasera	Posição   Freio   Direcional Position   Brake   Directional Posición   Freno   Direccional	
8119.83.306		Selado 3 Vias 3 Pin Sealed - Sellado de 3 Vias		Ré   Neblina Reverse   Fog - Reversa   Niebla	



## 8126 | Lanterna DRL Ø83

Ø83 DRL | Luz DRL Ø83

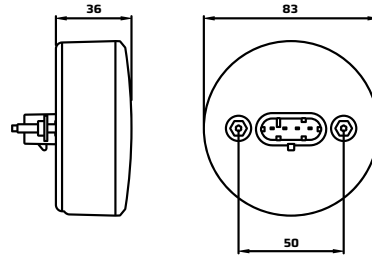

Código <small>Code - Código</small>	Tensão <small>Voltage - Voltaje</small>	Conexão <small>Connection - Conexión</small>	Fixação <small>Fixation - Fijación</small>	Funções <small>Functions - Funciones</small>	Observação <small>Observation - Observación</small>
8126.80.305	12/24V	Selada 4 Vias <small>4-Pin Sealed - Sellada de 4 Vias</small>	Traseira <small>Rear - Trasera</small>	Posição   Direcional   DRL <small>Position   Directional   DRL</small> Posição   Direcional   DRL	Abas de Fixação <small>Mounting Tabs - Pestillos de Fijación</small>
8126.81.305					



## 8543 | Lanterna DRL Curva

Curve DRL Light | Luz DRL Curva

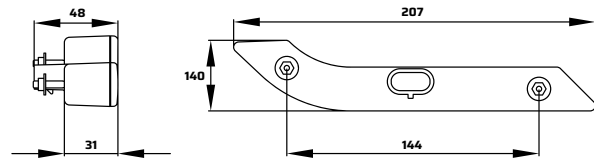
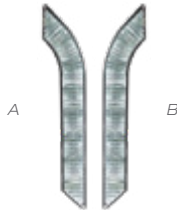

Lado A <small>Side A - Lado A</small>	Lado B <small>Side B - Lado B</small>	Tensão <small>Voltage - Voltaje</small>	Conexão <small>Connection - Conexión</small>	Fixação <small>Fixation - Fijación</small>	Funções <small>Functions - Funciones</small>
8543.60.305	8543.61.305	12V	Selada 3 Vias <small>3 Pin Sealed - Sellada de 3 Vias</small>	Traseira <small>Rear - Trasera</small>	Posição   DRL <small>Position   DRL - Posición   DRL</small>
8543.62.305	8543.63.305				Posição   Direcional <small>Position   Directional</small> Posição   Direcional
8543.70.305	8543.71.305	24V			Posição   DRL <small>Position   DRL - Posición   DRL</small>

Original  
STARA, PLASMOSUL



## 8965 | Lanterna DRL

DRL Light | Luz DRL

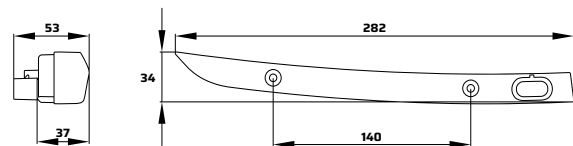

Direito <small>Code - Código</small>	Esquerdo <small>Voltage - Voltaje</small>	Tensão <small>Voltage - Voltaje</small>	Conexão <small>Connection - Conexión</small>	Fixação <small>Fixation - Fijación</small>	Funções <small>Functions - Funciones</small>	Observação <small>Observation - Observación</small>
8965.70.305	8965.71.305	24V	Selada 3 Vias <small>3 Pin Sealed - Sellada de 3 Vias</small>	Traseira <small>Rear - Trasera</small>	Posição   DRL <small>Position   DRL - Posición   DRL</small>	-

Original  
COMIL



## 8530 | Lanterna Posição | DRL

Universal Modular Light | Luz Modular Universal

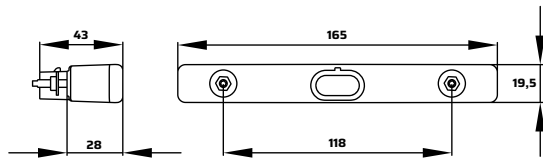

Código <small>Code - Código</small>	Tensão <small>Voltage - Voltaje</small>	Conexão <small>Connection - Conexión</small>	Fixação <small>Fixation - Fijación</small>	Funções <small>Functions - Funciones</small>	Observação <small>Observation - Observación</small>
□ 8530.88.305	12/24V	Selada 3 Vias <small>3-Pin Sealed - Sellado de 3 Vias</small>	Traseira <small>Rear - Trasera</small>	Posição   DRL <small>Position   DRL - Posición   DRL</small>	-

Original  
RANDON IMP



## 8530 | Lanterna Universal

Universal Modular Light | Luz Modular Universal

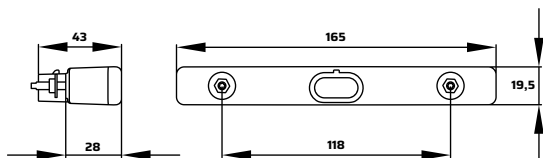

Código <small>Code - Código</small>	Tensão <small>Voltage - Voltaje</small>	Conexão <small>Connection - Conexión</small>	Fixação <small>Fixation - Fijación</small>	Funções <small>Functions - Funciones</small>	Observação <small>Observation - Observación</small>
■ 8530.74.301	24V	Selada 3 Vias <small>3-Pin Sealed - Sellado de 3 Vias</small>	Traseira <small>Rear - Trasera</small>	Posição   Freio   Direcional <small>Position   Steering   Directional Posición   Freno   Direccional</small>	-
■ 8530.74.302					

Original  
RANDON IMP



## 8530 | Lanterna Universal

Universal Modular Light | Luz Modular Universal

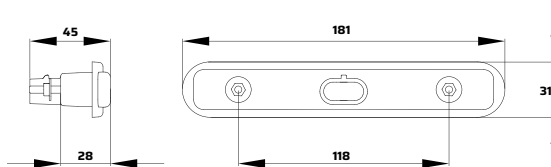

Código <small>Code - Código</small>	Tensão <small>Voltage - Voltaje</small>	Conexão <small>Connection - Conexión</small>	Fixação <small>Fixation - Fijación</small>	Funções <small>Functions - Funciones</small>	Observação <small>Observation - Observación</small>
■ 8530.74.302	24V	Selada 3 Vias <small>3 Pin Sealed - Sellado de 3 Vias</small>	Traseira <small>Rear - Trasera</small>	Posição   Freio <small>Position   Steering - Posición   Direccional</small>	-
■ 8530.80.302				Neblina <small>Fog - Niebla</small>	
■ 8530.82.301	12/24V	Selada 3 Vias <small>3 Pin Sealed - Sellado de 3 Vias</small>	Traseira <small>Rear - Trasera</small>	Direccional <small>Directional - Direccional</small>	
□ 8530.84.305				Posição   DRL <small>Position   DRL - Posición   DRL</small>	
□ 8530.88.305					

Original  
MASCARELLO



## 8542 | Lanterna Linear

Linear Light | Luz Linear

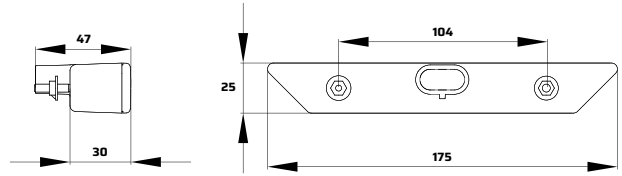

Código <i>Code - Código</i>	Tensão <i>Voltage - Voltaje</i>	Conexão <i>Connection - Conexión</i>	Fixação <i>Fixation - Fijación</i>	Funções <i>Functions - Funciones</i>	Observação <i>Observation - Observación</i>
<input checked="" type="checkbox"/> 8542.70.302	24V	Selada 3 Vias <i>3 Pin Sealed - Sellado de 3 Vias</i>	Traseira <i>Rear - Trasera</i>	Posição   Freio <i>Position   Brake - Posición   Freno</i>	-
<input type="checkbox"/> 8542.70.305				Posição   DRL <i>Position   DRL - Posición   DRL</i>	
<input type="checkbox"/> 8542.71.305				Ré <i>Reverse - Reversa</i>	

Original  
BEPO



## 8563 | Lanterna Mega Plus

Mega Plus Light | Luz Mega Plus

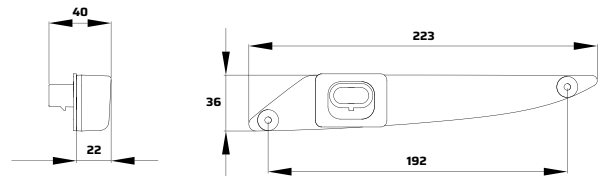

Lado A <i>Side A - Lado A</i>	Lado B <i>Side B - Lado B</i>	Tensão <i>Voltage - Voltaje</i>	Conexão <i>Connection - Conexión</i>	Fixação <i>Fixation - Fijación</i>	Funções <i>Functions - Funciones</i>
<input checked="" type="checkbox"/> 8563.70.301	8563.71.301	24V	Selada 3 Vias <i>3 Pin Sealed - Sellado de 3 Vias</i>	Frontal <i>Front - Frontal</i>	Direcional <i>Directional - Direccional</i>
<input checked="" type="checkbox"/> 8563.70.302	8563.71.302				Posição   Freio <i>Position   Steering - Posición   Direccional</i>
<input type="checkbox"/> 8563.70.305	8563.71.305				DRL <i>DRL - DRL</i>

Original  
Marcopolo



## 8938 | Lanterna Ø75mm

Ø75mm Light | Luz Ø75mm

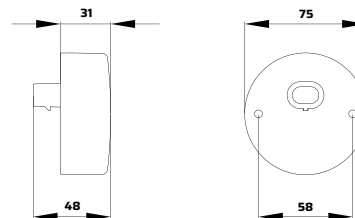

Código <i>Code - Código</i>	Tensão <i>Voltage - Voltaje</i>	Conexão <i>Connection - Conexión</i>	Fixação <i>Fixation - Fijación</i>	Funções <i>Functions - Funciones</i>	Observação <i>Observation - Observación</i>
8938.80.305	12/24V	Selada 2 Vias <i>2 Pin Sealed - Sellado de 2 Vias</i>	Frontal <i>Front - Frontal</i>	Ré <i>Reverse - Reversa</i>	-
8938.80.315				Direcional <i>Directional - Direccional</i>	

Original  
Marcopolo



## 8907 | Lanterna Ø70mm

Ø70mm Light | Luz Ø70mm

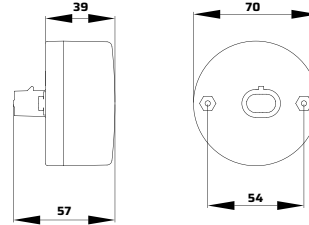

Código <small>Code - Código</small>	Tensão <small>Voltage - Voltaje</small>	Conexão <small>Connection - Conexión</small>	Fixação <small>Fixation - Fijación</small>	Funções <small>Functions - Funciones</small>	Observação <small>Observation - Observación</small>
8907.71.301	12/24V	Selada 2 Vias <small>2 Pin Sealed - Sellado de 2 Vias</small>	Traseira <small>Rear - Trasera</small>	Direcional Traseiro <small>Rear Directional - Direccional Trasera</small>	-
8907.71.302		Selada 3 Vias <small>3 Pin Sealed - Sellado de 3 Vias</small>		Posição   Freio <small>Position   Steering - Posición   Direccional</small>	
8907.73.302		Selada 2 Vias <small>2 Pin Sealed - Sellado de 2 Vias</small>		Neblina <small>Fog - Niebla</small>	
8907.73.315		Direcional Dianteiro <small>Front Directional - Direccional Delantera</small>		LED âmbar	
8907.75.305		DRL <small>DRL - DRL</small>		-	

Original

RANDON, MASCARELLO, VOLARE, COMIL, LIBRELATO



## 8115 | Lanterna Scarlatt

Scarlatt Rear Light | Luz Trazera Scarlatt

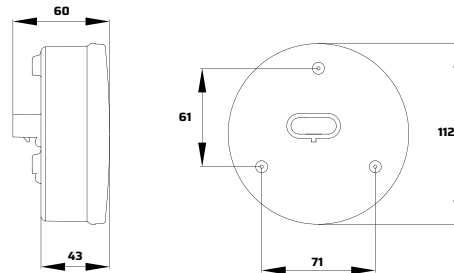

Código <small>Code - Código</small>	Tensão <small>Voltage - Voltaje</small>	Conexão <small>Connection - Conexión</small>	Fixação <small>Fixation - Fijación</small>	Funções <small>Functions - Funciones</small>	Observação <small>Observation - Observación</small>
8115.84.325	12/24V	Selada 4 Vias <small>4-Pin Sealed - Sellado de 4 Vias</small>	Traseira <small>Rear - Trasera</small>	Posição   Freio   Direcional <small>Position   Brake   Turn Signal - Posición   Frena   Direccional</small>	-
8115.85.325		Selada 2 Vias <small>2 Pin Sealed - Sellado de 2 Vias</small>		Ré   Retro <small>Reverse   Reverse Light - Reversa   Luz de Reversa</small>	
8115.86.325		Selada 4 Vias <small>4-Pin Sealed - Sellado de 4 Vias</small>		Neblina   Retro <small>Fog   Reverse Light - Niebla   Luz de Reversa</small>	
8115.87.325		Selada 4 Vias <small>4-Pin Sealed - Sellado de 4 Vias</small>		Posição   Ré   Neblina   Retro <small>Position   Reverse   Fog   Reverse Light - Posición   Reversa   Niebla   Luz de Réver</small>	

Original

SANTO INÁCIO



## 8106 | Lanterna Vitra 96

Vitra 96 Light | Luz Vitra 96

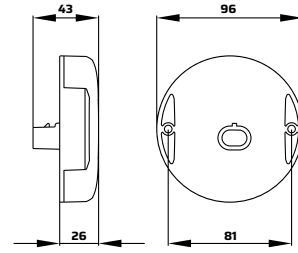

Código <small>Code - Código</small>	Tensão <small>Voltage - Voltaje</small>	Conexão <small>Connection - Conexión</small>	Fixação <small>Fixation - Fijación</small>	Funções <small>Functions - Funciones</small>	Observação <small>Observation - Observación</small>
8106.80.301	12/24V	Selada 2 Vias <small>2 Pin Sealed - Sellado de 2 Vias</small>	Frontal <small>Front - Frontal</small>	Direcional <small>Steering - Direccional</small>	-
8106.80.302		Selada 3 Vias <small>Pin Sealed - Sellado de 3 Vias</small>		Posição   Freio <small>Position   Steering - Posición   Freno</small>	
8106.80.305		Selada 2 Vias <small>2 Pin Sealed - Sellado de 2 Vias</small>		Ré <small>Reverse - Reversa</small>	



## 8109 | Lanterna Vitra 122

Vitra 122 Light | Luz Vitra 122

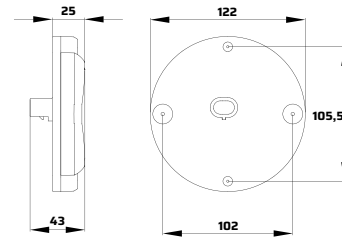

Código <small>Code - Código</small>	Tensão <small>Voltage - Voltaje</small>	Conexão <small>Connection - Conexión</small>	Fixação <small>Fixation - Fijación</small>	Funções <small>Functions - Funciones</small>	Observação <small>Observation - Observación</small>
8109.80.301	12/24V	Selada 2 Vias <small>2 Pin Sealed - Sellado de 2 Vias</small>	Traseira   Frontal <small>Rear   Front - Trasera   Frontal</small>	Direcional <small>Steering - Direccional</small>	-
8109.80.302		Selada 3 Vias <small>Pin Sealed - Sellado de 3 Vias</small>		Posição   Freio <small>Position   Steering - Posición   Freno</small>	
8109.80.305		Selada 2 Vias <small>2 Pin Sealed - Sellado de 2 Vias</small>		Ré <small>Reverse - Reversa</small>	



## 8560 | Lanterna Dianteira Direcional

Front Turn Light | Luz Delantera de Direccional

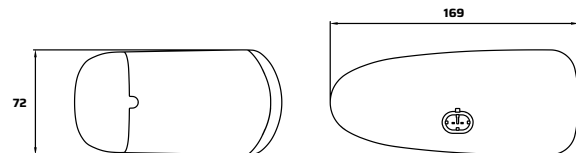

Código <small>Code - Código</small>	Tensão <small>Voltage - Voltaje</small>	Conexão <small>Connection - Conexión</small>	Fixação <small>Fixation - Fijación</small>	Funções <small>Functions - Funciones</small>	Observação <small>Observation - Observación</small>
8560.80.301	12/24V	Selada 2 Vias <small>2 Pin Sealed - Sellado de 2 Vias</small>	Traseira <small>Rear - Trasera</small>	Dianteiro <small>Front - Delantera</small>	-



## 8570 | Lanterna 4"

4" Light | Luz 4"

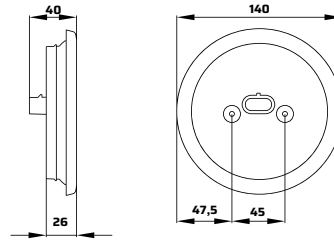

Código <small>Code - Código</small>	Tensão <small>Voltage - Voltaje</small>	Conexão <small>Connection - Conexión</small>	Fixação <small>Fixation - Fijación</small>	Funções <small>Functions - Funciones</small>	Observação <small>Observation - Observación</small>
8570.85.301	12/24V	Selado 3 Vias <small>3 Pin Sealed - Sellado de 3 Vias</small>	Frontal <small>Front - Frontal</small>	Direcional <small>Directional - Direccional</small>	-
8570.85.302				Posição   Freio <small>Position   Steering - Posición   Freno</small>	
8570.85.305				Ré <small>Reverse - Reversa</small>	



## 8570 | Lanterna 4"

4" Light | Luz 4"

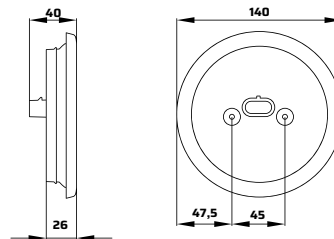

Código <small>Code - Código</small>	Tensão <small>Voltage - Voltaje</small>	Conexão <small>Connection - Conexión</small>	Fixação <small>Fixation - Fijación</small>	Funções <small>Functions - Funciones</small>	Observação <small>Observation - Observación</small>
8570.86.301	12/24V	Selado 3 Vias <small>3 Pin Sealed - Sellado de 3 Vias</small>	Embutir <small>Built-in - Empatrado</small>	Direcional <small>Directional - Direccional</small>	-
8570.86.302				Posição   Freio <small>Position   Steering - Posición   Freno</small>	
8570.86.305				Ré <small>Reverse - Reversa</small>	



## 8057 | Lanterna Ø 155mm

Ø 155mm Light | Luz Ø 155mm

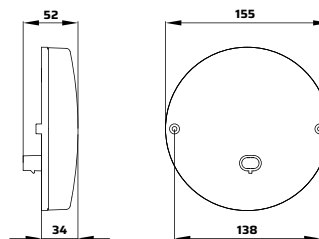

Código <small>Code - Código</small>	Tensão <small>Voltage - Voltaje</small>	Conexão <small>Connection - Conexión</small>	Fixação <small>Fixation - Fijación</small>	Funções <small>Functions - Funciones</small>	Observação <small>Observation - Observación</small>
8057.81.301	12/24V	Selado 2 Vias <small>2 Pin Sealed - Sellado de 2 Vias</small>	Frontal <small>Front - Frontal</small>	Direcional <small>Steering - Direccional</small>	-
8057.81.302		Selado 3 Vias <small>Pin Sealed - Sellado de 3 Vias</small>		Posição   Freio <small>Position   Steering - Posición   Freno</small>	
8057.81.305		Selado 2 Vias <small>2 Pin Sealed - Sellado de 2 Vias</small>		Ré <small>Reverse - Reversa</small>	



Original  
CAIO

## 8056 | Lanterna Ø 155mm

Ø 155mm Light | Luz Ø 155mm

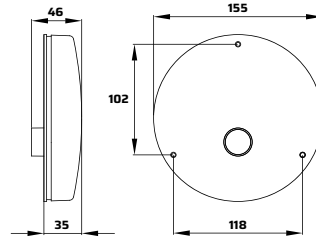

Código <small>Code - Código</small>	Tensão <small>Voltage - Voltaje</small>	Conexão <small>Connection - Conexión</small>	Fixação <small>Fixation - Fijación</small>	Funções <small>Functions - Funciones</small>	Observação <small>Observation - Observación</small>
■ 8056.72.302	24V	3 Terminais Lingueta 6,3mm 3 Terminals Tab 6.3mm	Traseira <small>Rear - Trasera</small>	Posição   Freio <small>Position   Steering - Posición   Freno</small>	-
□ ■ 8056.73.325		4 Terminais Lingueta 6,3mm 4 Terminals Tab 6.3mm		Posição   Freio   Ré <small>Position   Steering   Reverse - Posición   Freno   Reversa</small>	
□ 8056.80.302	12/24V	3 Terminais Lingueta 6,3mm 3 Terminals Tab 6.3mm		Posição   Freio <small>Position   Steering - Posición   Freno</small>	

Original  
NOMA



## 8135 | Lanterna DUO Light

DUO Light | Luz DUO Light

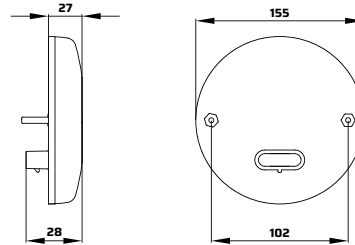

Código <small>Code - Código</small>	Tensão <small>Voltage - Voltaje</small>	Conexão <small>Connection - Conexión</small>	Fixação <small>Fixation - Fijación</small>	Funções <small>Functions - Funciones</small>	Observação <small>Observation - Observación</small>
■ ■ 8135.80.321	12/24V	Selada 4 Vias 4 Pin Sealed - Sellada de 4 Vias	Traseira <small>Rear - Trasera</small>	Posição   Freio   Direcional <small>Position   Brake   Turn Signal - Posición   Freno   Direccional</small>	-
□ ■ 8135.80.325				Posição   Freio   Ré <small>Position   Steering   Reverse - Posición   Freno   Reversa</small>	
□ ■ 8135.82.325		Selada 5 Vias 5 Pin Sealed - Sellada de 5 Vias		Posição   Freio   Direccional   Ré <small>Position   Brake   Turn Signal   Reverse - Posición   Freno   Direccional   Reversa</small>	

Original  
LIBRELATO, JACTO, AGRALE



## 8044 | Lanterna Ø 125mm

Ø 125mm Light | Luz Ø 125mm

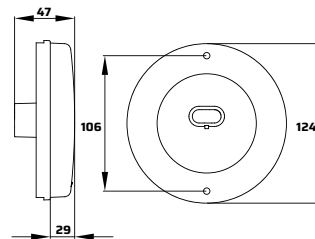

Código <small>Code - Código</small>	Tensão <small>Voltage - Voltaje</small>	Conexão <small>Connection - Conexión</small>	Fixação <small>Fixation - Fijación</small>	Funções <small>Functions - Funciones</small>	Observação <small>Observation - Observación</small>
■ 8044.80.301	12/24V	Selada 2 Vias 2 Pin Sealed - Sellada de 2 Vias	Frontal <small>Front - Frontal</small>	Direccional <small>Steering - Direccional</small>	-
■ 8044.80.302		Selada 3 Vias 3 Pin Sealed - Sellada de 3 Vias		Posição   Freio <small>Position   Steering - Posición   Freno</small>	
□ 8044.80.305		Selada 2 Vias 2 Pin Sealed - Sellada de 2 Vias		Ré <small>Reverse - Reversa</small>	
■ 8044.81.302		Selada 3 Vias 3 Pin Sealed - Sellada de 3 Vias		Posição   Freio <small>Position   Steering - Posición   Freno</small>	

Original  
CAMIL, MASCARELLO, MAHINDRA, MARCOPOLO



## 8049 | Lanterna Ø 110mm

Ø 110mm Light | Luz Ø 110mm

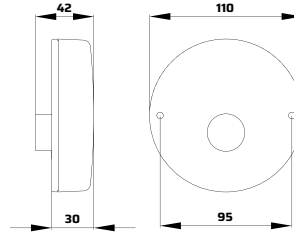

Código <small>Code - Código</small>	Tensão <small>Voltage - Voltaje</small>	Conexão <small>Connection - Conexión</small>	Fixação <small>Fixation - Fijación</small>	Funções <small>Functions - Funciones</small>	Observação <small>Observation - Observación</small>	
8049.70.301	24V	2 Terminais Lingueta 6,3mm 2 Terminals Tab 6,3mm 2 Terminales Lengüeta 6,3mm	Frontal <i>Front - Frontal</i>	Direcional <i>Steering - Direccional</i>	-	
8049.70.302		3 Terminais Lingueta 6,3mm 3 Terminals Tab 6,3mm 3 Terminales Lengüeta 6,3mm		Posição   Freio <i>Position   Steering - Posición   Freno</i>		
8049.70.305		2 Terminais Lingueta 6,3mm 2 Terminals Tab 6,3mm 2 Terminales Lengüeta 6,3mm		Ré <i>Reverse - Reversa</i>		
8049.70.315		2 Terminais Lingueta 6,3mm 2 Terminals Tab 6,3mm 2 Terminales Lengüeta 6,3mm		Direcional <i>Steering - Direccional</i>		LED Âmbar
8049.70.325		3 Terminais Lingueta 6,3mm 3 Terminals Tab 6,3mm 3 Terminales Lengüeta 6,3mm		Posição   Freio <i>Position   Steering - Posición   Freno</i>		LED Rubi

Original  
LIBRELATO



## 8049 | Lanterna Ø 110mm com aba

Ø110 mm Rear Light with Flange | Luz Trasera Ø110 mm con Aleta

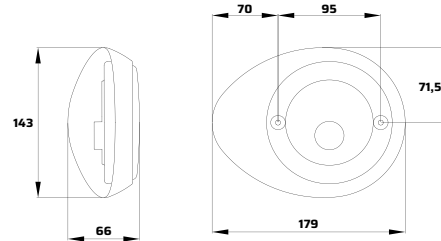

Código <small>Code - Código</small>	Tensão <small>Voltage - Voltaje</small>	Conexão <small>Connection - Conexión</small>	Fixação <small>Fixation - Fijación</small>	Funções <small>Functions - Funciones</small>	Observação <small>Observation - Observación</small>
8049.72.301	24V	2 Terminais Lingueta 6,3mm 2 Terminals Tab 6,3mm 2 Terminales Lengüeta 6,3mm	Frontal <i>Front - Frontal</i>	Direcional <i>Steering - Direccional</i>	-
8049.72.302		3 Terminais Lingueta 6,3mm 3 Terminals Tab 6,3mm 3 Terminales Lengüeta 6,3mm		Posição   Freio <i>Position   Steering - Posición   Freno</i>	
8049.72.305		2 Terminais Lingueta 6,3mm 2 Terminals Tab 6,3mm 2 Terminales Lengüeta 6,3mm		Ré <i>Reverse - Reversa</i>	

Original  
MARCOPOLO



## 8048 | Lanterna Ø 96mm

Ø 96mm Light | Luz Ø 96mm

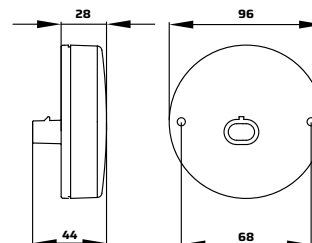

Código <small>Code - Código</small>	Tensão <small>Voltage - Voltaje</small>	Conexão <small>Connection - Conexión</small>	Fixação <small>Fixation - Fijación</small>	Funções <small>Functions - Funciones</small>	Observação <small>Observation - Observación</small>
8048.80.301	12/24V	Selada 2 Vias 2 Pin Sealed - Sellada de 2 Vias	Frontal <i>Front - Frontal</i>	Direcional <i>Steering - Direccional</i>	-
8048.80.302		Selada 3 Vias 3 Pin Sealed - Sellada de 3 Vias		Posição   Freio <i>Position   Steering - Posición   Freno</i>	
8048.82.305		Selada 2 Vias 2 Pin Sealed - Sellada de 2 Vias		Ré <i>Reverse - Reversa</i>	

Original  
MARCOPOLO, CAIO, VOLARE



## 8926 | Lanterna Ø 96mm

Ø 96mm Rear Light | Luz Trasera Ø 96mm

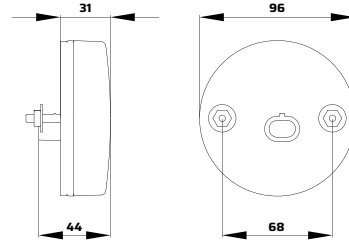

Código <small>Code - Código</small>	Tensão <small>Voltage - Voltaje</small>	Conexão <small>Connection - Conexión</small>	Fixação <small>Fixation - Fijación</small>	Funções <small>Functions - Funciones</small>	Observação <small>Observation - Observación</small>	
8926.40.301	12V	Selado 2 Vias 2 Pin Sealed - Sellado de 2 Vias	Traseira Rear - Trasera	Direcional Steering - Direccional		
8926.80.301				Posição   Freio Position   Steering - Posición   Freno		
8926.80.302		Selado 3 Vias 3 Pin Sealed - Sellado de 3 Vias		Rê Reverse - Reversa		
8926.80.305		Selado 2 Vias 2 Pin Sealed - Sellado de 2 Vias		Direcional Steering - Direccional		LED Âmbar
8926.80.315		Selado 3 Vias 3 Pin Sealed - Sellado de 3 Vias		Posição   Freio Position   Steering - Posición   Freno		LED Rubi
8926.80.325						

Original  
IRIZAR



## 8517 | Lanterna DUO Ø 125mm

DUO Ø 125mm Light | Luz DUO Ø 125mm

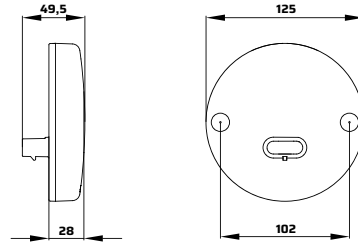

Código <small>Code - Código</small>	Tensão <small>Voltage - Voltaje</small>	Conexão <small>Connection - Conexión</small>	Fixação <small>Fixation - Fijación</small>	Funções <small>Functions - Funciones</small>	Observação <small>Observation - Observación</small>
8517.71.321	24V	Selado 4 Vias 4 Pin Sealed - Sellado de 4 Vias	Traseira Rear - Trasera	Posição   Freio   Direcional Position   Brake   Turn Signal Posición   Freno   Direccional	
8517.71.325				Posição   Freio   Ré Position   Brake   Reverse Posición   Freno   Reversa	



## 8572 | Lanterna Curva

Curve Light | Luz Curva

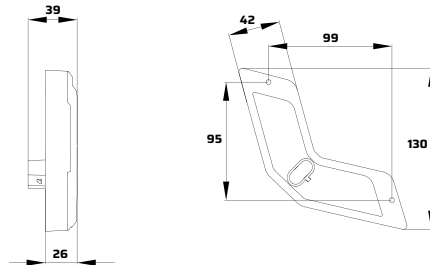

Código <small>Code - Código</small>	Tensão <small>Voltage - Voltaje</small>	Conexão <small>Connection - Conexión</small>	Fixação <small>Fixation - Fijación</small>	Funções <small>Functions - Funciones</small>	Observação <small>Observation - Observación</small>
8572.70.301	24V	Selado 3 Vias 3 Pin Sealed - Sellado de 3 Vias	Frontal Front - Frontal	Direcional Steering - Direccional	
8572.70.302				Posição   Freio Position   Steering - Posición   Freno	
8572.70.305				Rê Reverse - Reversa	

Original  
COMIL



## 8578 | Lanterna Elíptica I

Elíptica I Light | Luz Elíptica I

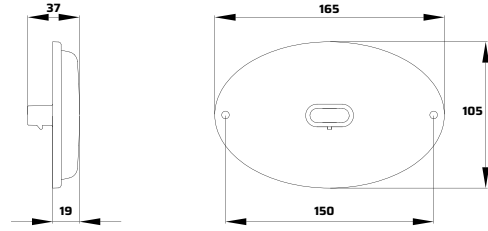

Código <small>Code - Código</small>	Tensão <small>Voltage - Voltaje</small>	Conexão <small>Connection - Conexión</small>	Fixação <small>Fixation - Fijación</small>	Funções <small>Functions - Funciones</small>	Observação <small>Observation - Observación</small>
8578.60.315	12V	Selada 4 Vias 4 Pin Sealed - Sellado de 4Vias	Frontal <i>Front - Frontal</i>	Posição   Direcional <i>Position   Turn Signal - Posición   Direccional</i>	Dianteira <i>Front - Delantera</i>
8578.60.321				Posição   Freio   Direcional <i>Position   Steering   Turn Signal - Posición   Freno   Direccional</i>	Traseira <i>Rear - Trasera</i>
8578.62.315			Suporte <i>Support - Soporte</i>		Com Chicote auxiliar Deutsch 4 vias <i>With Auxiliary Deutsch 4-Way Harness - Con Chicote Auxiliar Deutsch de 4 Vias</i>
8578.62.321			Frontal <i>Front - Frontal</i>		

Original  
AGCO, ARAL, VENCE TUDO



## 8579 | Lanterna Elíptica II

Elíptica II Light | Luz Elíptica II

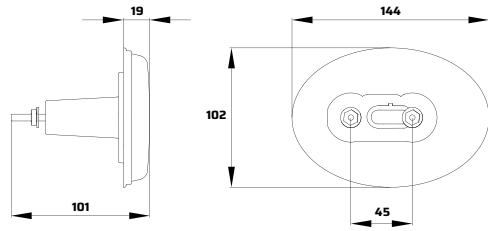

Código <small>Code - Código</small>	Tensão <small>Voltage - Voltaje</small>	Conexão <small>Connection - Conexión</small>	Fixação <small>Fixation - Fijación</small>	Funções <small>Functions - Funciones</small>	Observação <small>Observation - Observación</small>
8579.60.321	12V	Selada 4 Vias 4 Pin Sealed - Sellado de 4Vias	Traseira <i>Rear - Trasera</i>	Posição   Freio   Direcional <i>Position   Steering   Turn Signal - Posición   Freno   Direccional</i>	
8579.61.321		Deutsch 4 Vias 4 Pin Deutsch- Deutsch 4Vias			

Original  
AGCO



## 8518 | Lanterna Flex

Flex Light | Luz Flex

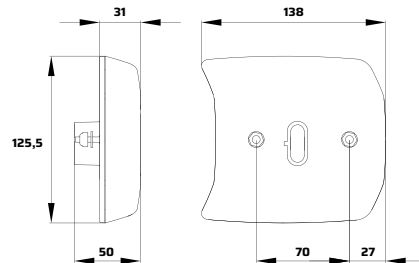

Código <small>Code - Código</small>	Tensão <small>Voltage - Voltaje</small>	Conexão <small>Connection - Conexión</small>	Fixação <small>Fixation - Fijación</small>	Funções <small>Functions - Funciones</small>	Observação <small>Observation - Observación</small>
8518.60.325	12V	Selada 4 Vias 4 Pin Sealed - Sellado de 4Vias	Traseira <i>Rear - Trasera</i>	Posição   Freio   Direcional <i>Position   Steering   Turn Signal - Posición   Freno   Direccional</i>	
8518.70.321	24V				
8518.71.321					

Original  
KUHN, SERGOMEL, IBIPORÃ



## 8905 | Lanterna Módulo Traseiro

Rear Module Light | Módulo de Luz Traseira V

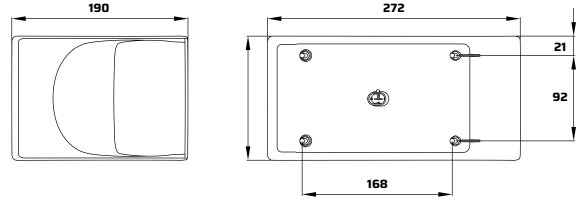

Código <small>Code - Código</small>	Tensão <small>Voltage - Voltaje</small>	Conexão <small>Connection - Conexión</small>	Fixação <small>Fixation - Fijación</small>	Funções <small>Functions - Funciones</small>	Observação <small>Observation - Observación</small>
8905.70.302	24V	Selada 3 Vias <small>3 Pin Sealed - Sellado de 3 Vias</small>	Traseira <small>Rear - Trasera</small>	Posição   Freio <small>Position   Steering - Posición   Freno</small>	-
8905.70.305		Selada 2 Vias <small>2 Pin Sealed - Sellado de 2 Vias</small>		Ré <small>Reverse - Reversa</small>	
8905.70.315				Direcional <small>Steering - Direccional</small>	

Original  
COMIL



## 8932 | Lanterna Modular

Modular Light | Luz Modular

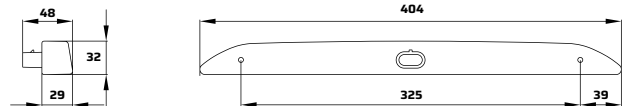

Código <small>Code - Código</small>	Tensão <small>Voltage - Voltaje</small>	Conexão <small>Connection - Conexión</small>	Fixação <small>Fixation - Fijación</small>	Funções <small>Functions - Funciones</small>	Observação <small>Observation - Observación</small>
8932.77.302	24V	Selada 3 Vias <small>3 Pin Sealed - Sellado de 3 Vias</small>	Embutir <small>Recessed - Empatrar</small>	Posição   Freio <small>Position   Steering - Posición   Freno</small>	10 LED

Original  
MARCOPOLO, NOMA



## 8932 | Lanterna Brake Light

Brake Light | Luz Brake Light

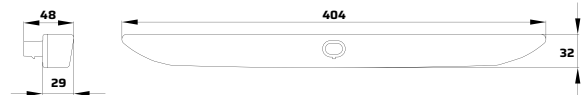

Código <small>Code - Código</small>	Tensão <small>Voltage - Voltaje</small>	Conexão <small>Connection - Conexión</small>	Fixação <small>Fixation - Fijación</small>	Funções <small>Functions - Funciones</small>	Observação <small>Observation - Observación</small>
8932.70.302	24V	Selada 2 Vias <small>2 Pin Sealed - Sellado de 2 Vias</small>	Embutir <small>Recessed - Empatrar</small>	Posição   Freio <small>Position   Steering - Posición   Freno</small>	12 LED
8932.73.305			Frontal <small>Front - Frontal</small>		10 LED

Original  
MARCOPOLO, NOMA



## 8980 | Lanterna Brake Light

Brake Light | Luz Brake Light

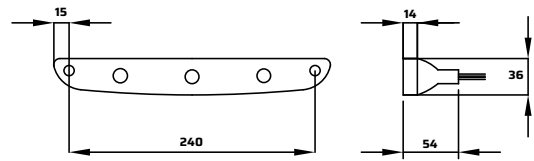

Código <small>Code - Código</small>	Tensão <small>Voltage - Voltaje</small>	Conexão <small>Connection - Conexión</small>	Fixação <small>Fixation - Fijación</small>	Funções <small>Functions - Funciones</small>	Observação <small>Observation - Observación</small>
8980.80.302	12/24V	Saída de Fios <small>Wire Outlet/Salida de Cables</small>	Frontal <small>Front - Frontal</small>	Posição   Freio <small>Position   Steering - Posición   Frena</small>	-

Original  
COMIL



## 8951 | Lanterna Brake Light

Brake Light | Luz Brake Light

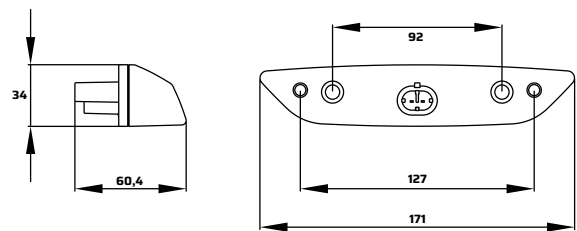

Código <small>Code - Código</small>	Tensão <small>Voltage - Voltaje</small>	Conexão <small>Connection - Conexión</small>	Fixação <small>Fixation - Fijación</small>	Funções <small>Functions - Funciones</small>	Observação <small>Observation - Observación</small>
8951.71.302	24V	Selada 2 Vias <small>2 Pin Sealed - Sellado de 2Vias</small>	Frontal <small>Front - Frontal</small>	Posição   Freio <small>Position   Brake - Posición   Frena</small>	-

Original  
MARCOPOLO



## 8933 | Lanterna Brake Light

Brake Light | Luz Brake Light

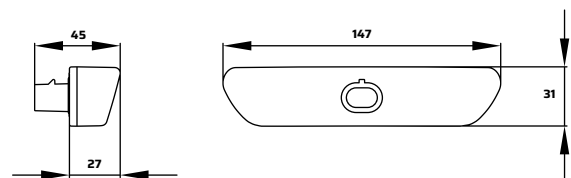

Código <small>Code - Código</small>	Tensão <small>Voltage - Voltaje</small>	Conexão <small>Connection - Conexión</small>	Fixação <small>Fixation - Fijación</small>	Funções <small>Functions - Funciones</small>	Observação <small>Observation - Observación</small>
8933.71.305	24V	Selada 2 Vias <small>2 Pin Sealed - Sellado de 2Vias</small>	Frontal <small>Front - Frontal</small>	Posição   Freio <small>Position   Brake - Posición   Frena</small>	-

Original  
MARCOPOLO



## 8952 | Lanterna Brake Light

Brake Light | Luz Brake Light

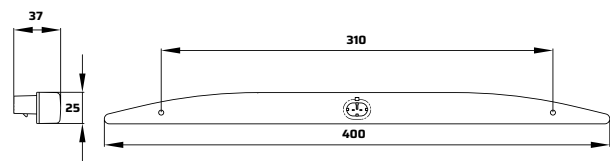

Código <small>Code - Código</small>	Tensão <small>Voltage - Voltaje</small>	Conexão <small>Connection - Conexión</small>	Fixação <small>Fixation - Fijación</small>	Funções <small>Functions - Funciones</small>	Observação <small>Observation - Observación</small>
8952.70.302	24V	Selada 2 Vias <small>2 Pin Sealed - Sellado de 2Vias</small>	Frontal <small>Front - Frontal</small>	Freio <small>Brake - Frena</small>	-

Original  
MARCOPOLO



## 8533 | Lanterna Brake Light

Brake Light | Luz Brake Light

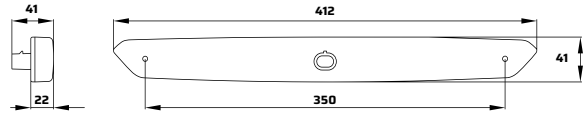

Código <small>Code - Código</small>	Tensão <small>Voltage - Voltaje</small>	Conexão <small>Connection - Conexión</small>	Fixação <small>Fixation - Fijación</small>	Funções <small>Functions - Funciones</small>	Observação <small>Observation - Observación</small>
8533.73.302	24V	Selado 2 Vias <small>2 Pin Sealed - Sellada de 2 Vias</small>	Frontal <small>Front - Frontal</small>	Posição   Freio <small>Position   Brake - Posición   Freno</small>	-



## 8070 | Lanterna Brake Light

Brake Light | Luz Brake Light

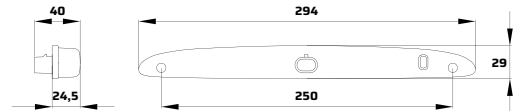

Código <small>Code - Código</small>	Tensão <small>Voltage - Voltaje</small>	Conexão <small>Connection - Conexión</small>	Fixação <small>Fixation - Fijación</small>	Funções <small>Functions - Funciones</small>	Observação <small>Observation - Observación</small>
8070.48.302	12V	Terminal Faston C Isolador 2Vias <small>Faston Terminal with Insulator 2-Way Terminal Faston con Aislador de 2 Vias</small>	Frontal <small>Front - Frontal</small>	Posição   Freio <small>Position   Steering - Posición   Freno</small>	300 mm
8070.49.302					1900 mm
8070.53.302	24V	Selado 2 Vias <small>2 Pin Sealed - Sellada de 2 Vias</small>			-

Original

RANDON, MASCARELLO, VOLARE, COMIL



## 8124 | Brakelight Ultraline

Brake Light Ultraline - Luz de Freno Ultraline

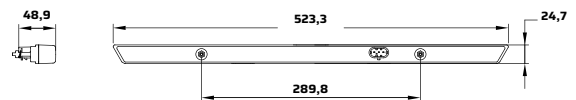

Código <small>Code - Código</small>	Tensão <small>Voltage - Voltaje</small>	Conexão <small>Connection - Conexión</small>	Fixação <small>Fixation - Fijación</small>	Funções <small>Functions - Funciones</small>	Observação <small>Observation - Observación</small>
8124.81.302	12/24V	Superseal 3 vias <small>Superseal 3-way - Superseal de 3 vias</small>	Traseira M5 <small>M5 Rear - Traseira M5</small>	Posição   Brakelight <small>Position - Posición</small>	-



## 8152 | Lanterna Brake Light Difusa

Diffuse Brake Light Lantern - Linterna de Luz de Freno Difusa

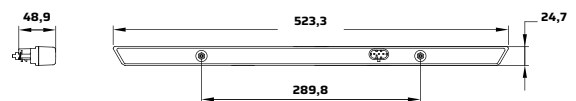

Código <small>Code - Código</small>	Tensão <small>Voltage - Voltaje</small>	Conexão <small>Connection - Conexión</small>	Fixação <small>Fixation - Fijación</small>	Funções <small>Functions - Funciones</small>	Observação <small>Observation - Observación</small>
8152.81.302	12/24V	Saída de fios <small>Wire Output - Salida de cables</small>	Frontal <small>Front - Frontal</small>	Freio <small>Brake - Freno</small>	-



# Lanternas delimitadoras e laterais

---

Com ampla variedade de estilos e opções de montagem, promovem segurança pela alta visibilidade nas estradas.

## ***Side markers and side turns***

*Wide variety of styles and mounting options, promoting safety and high visibility on the roads.*

## ***Luces perimetrales y laterales***

*Con amplia variedad de estilos y opciones de montaje, promueven seguridad por su alta visibilidad en las carreteras.*

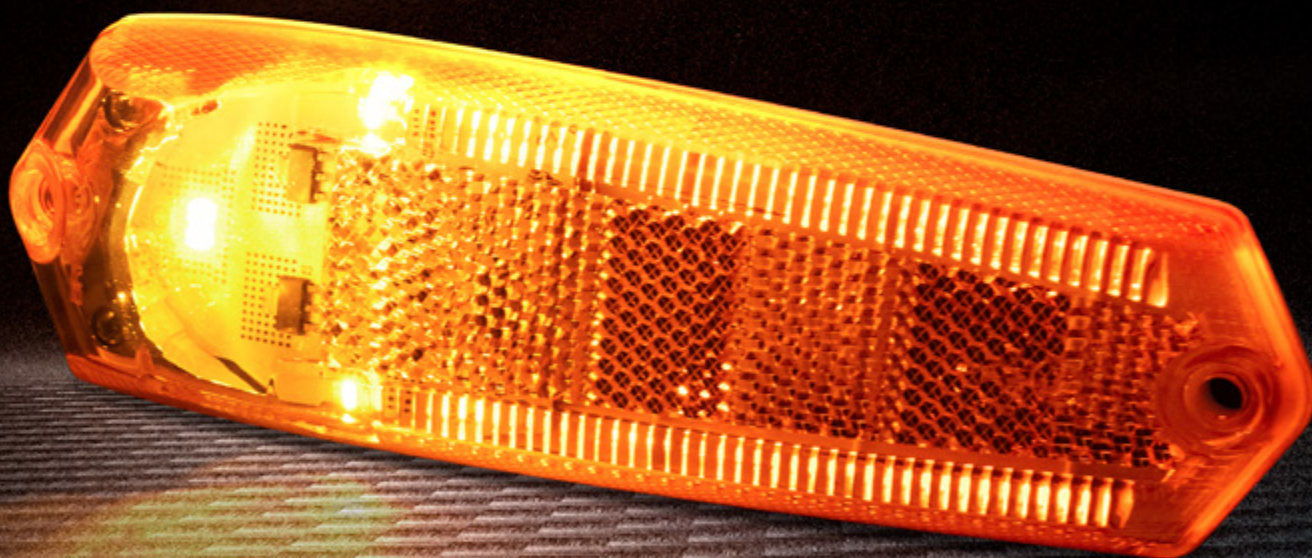

## 8114 | Lanterna End Out Line

End Out Line Light | Luz End Out Line

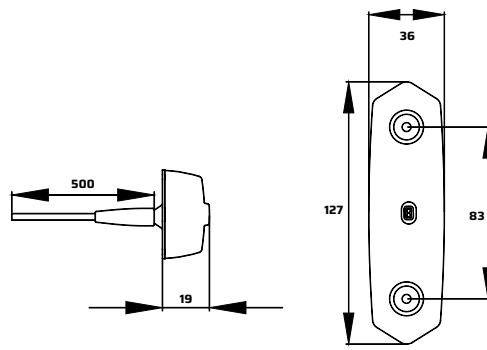

Código <i>Code - Código</i>	Tensão <i>Voltage - Voltaje</i>	Conexão <i>Connection - Conexión</i>	Fixação <i>Fixation - Fijación</i>	Funções <i>Functions - Funciones</i>	Observação <i>Observation - Observación</i>
8114.80.306	12/24V	Saída de Fios <i>Wire Outlet - Salida de Cables</i>	Frontal <i>Front - Frontal</i>	Posição <i>Position - Posición</i>	-



## 8552 | Lanterna Corneto

End out Line | Corneto

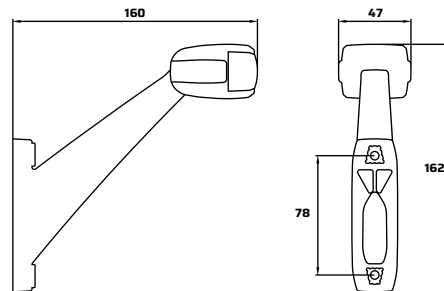

Direito <i>Code - Código</i>	Esquerdo <i>Voltage - Voltaje</i>	Tensão <i>Voltage - Voltaje</i>	Conexão <i>Connection - Conexión</i>	Fixação <i>Fixation - Fijación</i>	Funções <i>Functions - Funciones</i>	Observação <i>Observation - Observación</i>
8552.82.305	8552.83.305	12/24V	Saída de Fios <i>Wire Outlet - Salida de Cables</i>	Suporte <i>Bracket - Soporte</i>	Posição <i>Position - Posición</i>	Fios 1500mm <i>1500 mm Wires - Cables de 1500 mm</i>

Original  
GUERRA, NOMA, LIBRELATO



## 8070 | Lanterna Delimitadora

Marker Light | Luz Delimitadora

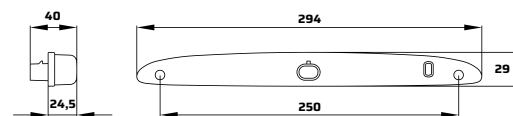

Código <i>Code - Código</i>	Tensão <i>Voltage - Voltaje</i>	Conexão <i>Connection - Conexión</i>	Fixação <i>Fixation - Fijación</i>	Funções <i>Functions - Funciones</i>	Observação <i>Observation - Observación</i>
8070.56.305	24V	Selado 2 Vias <i>2 Pin Sealed - Sellado de 2 Vias</i>	Frontal <i>Front - Frontal</i>	Posição   Freio <i>Position   Brake - Posición   Freno</i>	Fios 1500mm <i>1500mm Wires - Cables de 1500mm</i>

Original  
MASCARELLO, CAIO, COMIL, RANDON



## 8116 | Lanterna 8116

8116 Light | Luz 8116

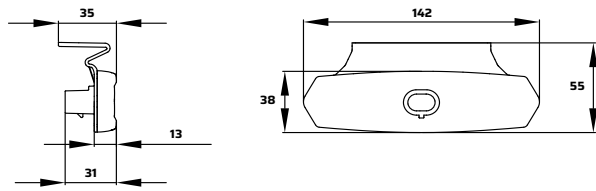

Código <i>Code - Código</i>	Tensão <i>Voltage - Voltaje</i>	Conexão <i>Connection - Conexión</i>	Fixação <i>Fixation - Fijación</i>	Funções <i>Functions - Funciones</i>	Observação <i>Observation - Observación</i>
 8116.80.301	12/24V	Selado 3 Vias 3 Pin Sealed - Sellado de 3 Vias	Suporte <i>Support - Soporte</i>	Posição   Retro <i>Position   Retroreflector</i> Posición   Retroceso	-
 8116.81.305			Traseira <i>Rear - Trasera</i>	Posição Dianteira   Retro <i>Front Position   Retroreflector</i> Posición Delantera   Retroceso	Sem Suporte <i>Without Support - No Soporte</i>

Original  
IBIPORÃ



## 8170 | Lanterna Side Marker

Side Marker Light | Luz Side Marker

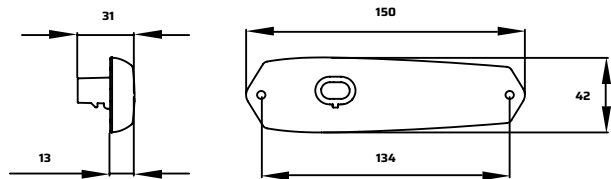

Código <i>Code - Código</i>	Tensão <i>Voltage - Voltaje</i>	Conexão <i>Connection - Conexión</i>	Fixação <i>Fixation - Fijación</i>	Funções <i>Functions - Funciones</i>	Observação <i>Observation - Observación</i>
8170.80.301	12/24V	Selado 2 Vias 2 Pin Sealed - Sellado de 2 Vias	Frontal <i>Front - Frontal</i>	Posição   Retrorrefletor <i>Position   Retroreflector</i> Posición   Retrorreflector	-

Original  
IRIZAR, ITALBUS



## 8171 | Lanterna Side Turn

Side Turn Light | Luz Side Turn

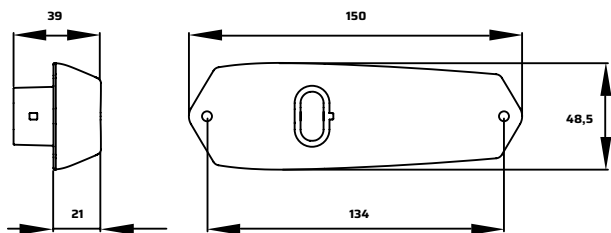

Código <i>Code - Código</i>	Tensão <i>Voltage - Voltaje</i>	Conexão <i>Connection - Conexión</i>	Fixação <i>Fixation - Fijación</i>	Funções <i>Functions - Funciones</i>	Observação <i>Observation - Observación</i>
8171.80.301	12/24V	Selado 3 Vias 3 Pin Sealed - Sellado de 3 Vias	Frontal <i>Front - Frontal</i>	Posição   Direcional   Retrorrefletor <i>Position   Turn Signal   Retroreflector</i> Posición   Direccional   Retrorreflector	-

Original  
IRIZAR, ITALBUS



## 8180 | Lanterna Side Marker

Side Marker Light | Luz Side Marker

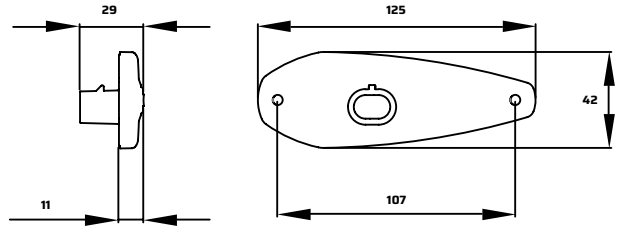

Código <i>Code - Código</i>	Tensão <i>Voltage - Voltaje</i>	Conexão <i>Connection - Conexión</i>	Fixação <i>Fixation - Fijación</i>	Funções <i>Functions - Funciones</i>	Observação <i>Observation - Observación</i>
<input checked="" type="checkbox"/> 8180.70.301 <input type="checkbox"/> 8180.71.305	24V	Selada 2 Vias 2 Pin Sealed - Sellado de 2 Vias	Frontal Front - Frontal	Posição   Retrorefletor Position   Retroreflector Posición   Retroreflector	-

Original  
IRIZAR



## 8580 | Lanterna Side Turn

Side Turn Light | Luz Side Turn

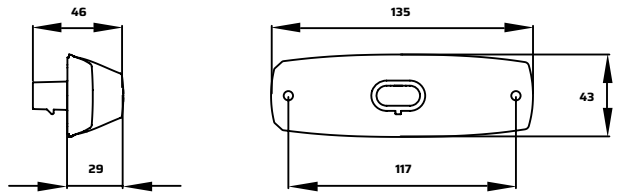

Código <i>Code - Código</i>	Tensão <i>Voltage - Voltaje</i>	Conexão <i>Connection - Conexión</i>	Fixação <i>Fixation - Fijación</i>	Funções <i>Functions - Funciones</i>	Observação <i>Observation - Observación</i>
8580.80.301	12/24V	Selada 3 Vias 3 Pin Sealed - Sellado de 3 Vias	Frontal Front - Frontal	Posição   Direcional   Retrorefletor Position   Turn Signal   Retroreflector Posición   Direccional   Retroreflector	-

Original  
CARBUS, COMIL



## 8524 | Lanterna Side Marker | Side Turn

Side Marker | Side Turn Light | Luz Side Marker | Side Turn

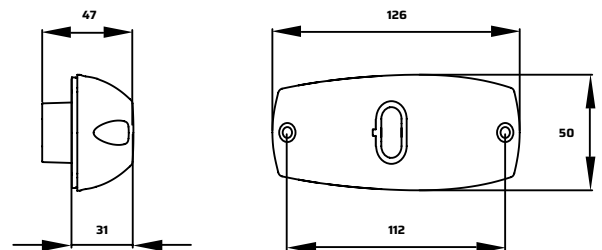

Código <i>Code - Código</i>	Tensão <i>Voltage - Voltaje</i>	Conexão <i>Connection - Conexión</i>	Fixação <i>Fixation - Fijación</i>	Funções <i>Functions - Funciones</i>	Observação <i>Observation - Observación</i>
8524.81.301	12/24V	Selada 3 Vias 3 Pin Sealed - Sellado de 3 Vias	Frontal Front - Frontal	Posição   Retrorefletor Position   Retroreflector Posición   Retroreflector	-



## 8916 | Lanterna Tech

Tech Light | Luz Tech

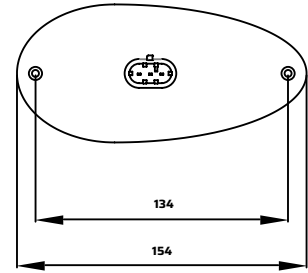
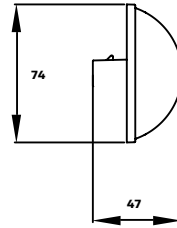

Código <i>Code - Código</i>	Tensão <i>Voltage - Voltaje</i>	Conexão <i>Connection - Conexión</i>	Fixação <i>Fixation - Fijación</i>	Funções <i>Functions - Funciones</i>	Observação <i>Observation - Observación</i>
8916.80.301	12/24V	Selada 3 Vias <i>3 Pin Sealed - Sellado de 3 Vias</i>	Frontal <i>Front - Frontal</i>	Posição   Direcional <i>Position   Turn Signal</i> <i>Posición   Direccional</i>	-

Original

MASCARELLO, IRIZAR, MARCOPOLO, COMIL, KUHN



## 8950 | Lanterna Posição

Position Light | Luz Posición

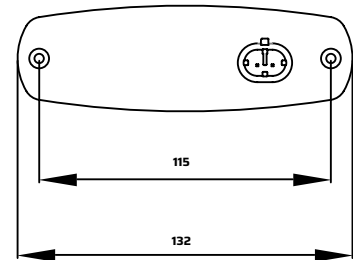
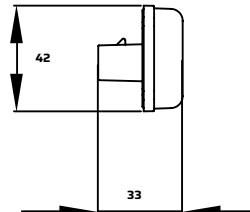

Código <i>Code - Código</i>	Tensão <i>Voltage - Voltaje</i>	Conexão <i>Connection - Conexión</i>	Fixação <i>Fixation - Fijación</i>	Funções <i>Functions - Funciones</i>	Observação <i>Observation - Observación</i>
8950.81.301	12/24V	Selada 2 Vias <i>2 Pin Sealed - Sellado de 2 Vias</i>	Frontal <i>Front - Frontal</i>	Posição   Retrorefletor <i>Position   Retroreflector</i> <i>Posición   Retroreflector</i>	-

Original

MARCOPOLO



## 8976 | Lanterna Delimitadora

Side Marker | Luz Delimitadora

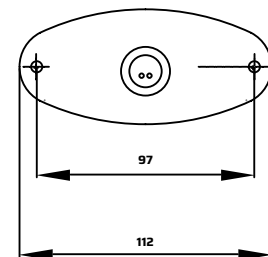
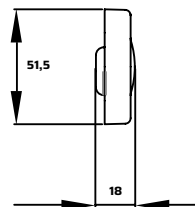
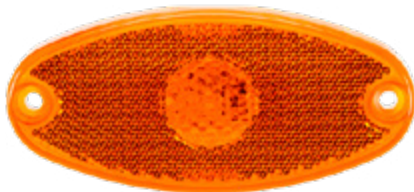

Código <i>Code - Código</i>	Tensão <i>Voltage - Voltaje</i>	Conexão <i>Connection - Conexión</i>	Fixação <i>Fixation - Fijación</i>	Funções <i>Functions - Funciones</i>	Observação <i>Observation - Observación</i>
8976.80.301	12/24V	Selada 3 Vias <i>3 Pin Sealed - Sellado de 3 Vias</i>	Frontal <i>Front - Frontal</i>	Posição   Retrorefletor <i>Position   Retroreflector</i> <i>Posición   Retroreflector</i>	-

Original

STARA, COMIL



## 8071 | Lanterna Posição | Retrorefletor

Position | Retroreflector Light | Luz Posición | Retroreflector

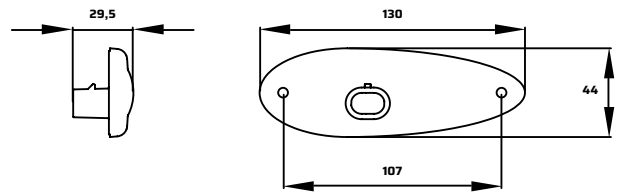

Código <i>Code - Código</i>	Tensão <i>Voltage - Voltaje</i>	Conexão <i>Connection - Conexión</i>	Fixação <i>Fixation - Fijación</i>	Funções <i>Functions - Funciones</i>	Observação <i>Observation - Observación</i>
8071.80.301	12/24V	Selado 2 Vias 2 Pin Sealed - Sellado de 2 Vias	Frontal Front - Frontal	Posição   Retrorefletor Position   Retroreflector Posición   Retroreflector	
8071.80.302					
8071.80.304					
8071.81.305		Saída de fios Wire Outlet - Salida de Cables			Fios 180mm 180mm Wires - Cables de 180mm

Original  
MASCARELLO, CAIO, COMIL, MARCOPOLO



## 8596 | Lanterna Delimitadora

Marker Light | Luz Delimitadora

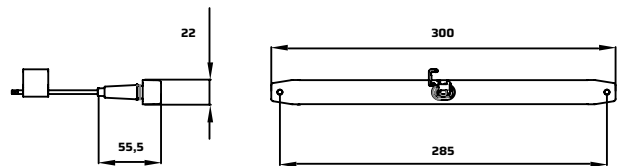
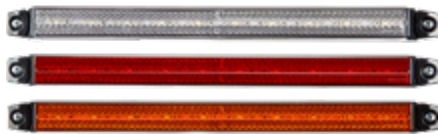

Código <i>Code - Código</i>	Tensão <i>Voltage - Voltaje</i>	Conexão <i>Connection - Conexión</i>	Fixação <i>Fixation - Fijación</i>	Funções <i>Functions - Funciones</i>	Observação <i>Observation - Observación</i>
8596.80.301	12/24V	Saída de fios Wire Outlet - Salida de Cables	Frontal Front - Frontal	Posição   Retrorefletor Position   Retroreflector Posición   Retroreflector	Fio 300mm com Snap IN 300mm Snap IN Wires Cables 300mm con Snap IN
8596.80.302					
8596.80.305					

Original  
RANDON, USICAMP



## 8969 | Lanterna Lateral Com Complemento

Side with Complement Light | Luz Lateral con Complemento

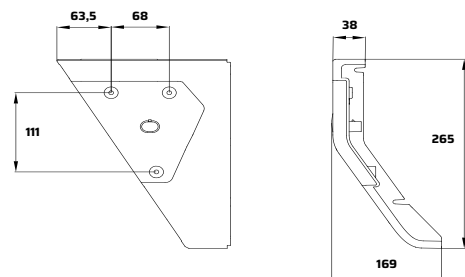

Direito <i>Code - Código</i>	Esquerdo <i>Voltage - Voltaje</i>	Tensão <i>Voltage - Voltaje</i>	Conexão <i>Connection - Conexión</i>	Fixação <i>Fixation - Fijación</i>	Funções <i>Functions - Funciones</i>	Observação <i>Observation - Observación</i>
8969.82.301	8969.83.301	12/24V	Selado 2 Vias 2 Pin Sealed - Sellado de 2 Vias	Traseira Rear - Trasera	Posição   Retrorefletor Position   Retroreflector Posición   Retroreflector	-

Original  
GUERRA



## 8522 | Lanterna Side Marker Com Aba

Side Marker With Flange Light | Luz Side Marker Com Pestaña

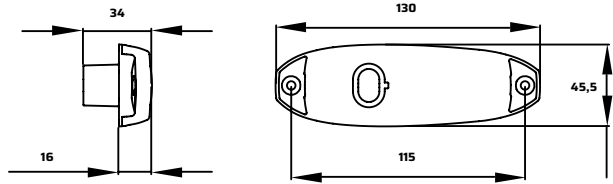

Código <i>Code - Código</i>	Tensão <i>Voltage - Voltaje</i>	Conexão <i>Connection - Conexión</i>	Fixação <i>Fixation - Fijación</i>	Funções <i>Functions - Funciones</i>	Observação <i>Observation - Observación</i>
8522.71.301	24V	Selado 2 Vias 2 Pin Sealed - Sellado de 2 Vias	Frontal Front - Frontal	Posição   Retrorrefletor Position   Retrorreflector Posición   Retrorreflector	-
8522.71.302					
8522.71.305					

Original  
IRIZAR, GRIMALDI



## 8547 | Lanterna Delimitadora

Side Marker | Luz Delimitadora

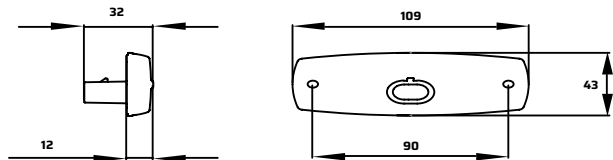

Código <i>Code - Código</i>	Tensão <i>Voltage - Voltaje</i>	Conexão <i>Connection - Conexión</i>	Fixação <i>Fixation - Fijación</i>	Funções <i>Functions - Funciones</i>	Observação <i>Observation - Observación</i>
8547.80.301	12 24V	Selado 2 Vias 2 Pin Sealed - Sellado de 2 Vias	Frontal Front - Frontal	Posição   Retrorrefletor Position   Retrorreflector Posición   Retrorreflector	-
8547.80.302					
8547.80.305					

Original  
LIBRELATO, ROSSETI



## 8547 | Lanterna Delimitadora com Suporte

Marker Light with Bracket | Luz Delimitadora con Soporte

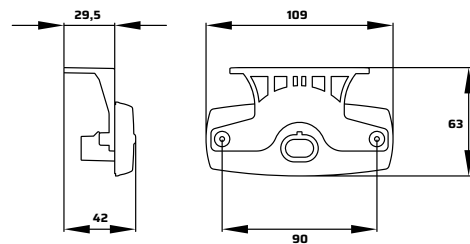

Código <i>Code - Código</i>	Tensão <i>Voltage - Voltaje</i>	Conexão <i>Connection - Conexión</i>	Fixação <i>Fixation - Fijación</i>	Funções <i>Functions - Funciones</i>	Observação <i>Observation - Observación</i>
8547.81.301	12/24V	Selado 2 Vias 2 Pin Sealed - Sellado de 2 Vias	Suporte Bracket - Soporte	Posição   Retro Position   Retro - Posición   Retro	-

Original  
NOSTRA, ROSSETTI, PASTRE



## 8516 | Lanterna Delimitadora

Side Marker | Luz Delimitadora

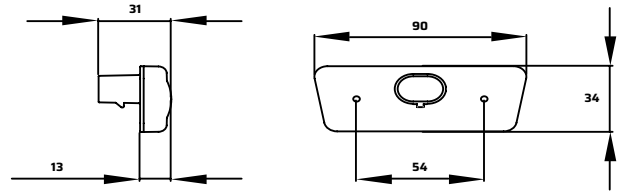

Código <i>Code - Código</i>	Tensão <i>Voltage - Voltaje</i>	Conexão <i>Connection - Conexión</i>	Fixação <i>Fixation - Fijación</i>	Funções <i>Functions - Funciones</i>	Observação <i>Observation - Observación</i>
8516.70.301	24V	Selada 2 Vias <i>2 Pin Sealed - Sellado de 2 Vías</i>	Embutir <i>Recessed - Empotrado</i>	Posição   Retrorrefletor <i>Position   Retroreflector</i> <i>Posición   Retrorreflector</i>	-

Original  
IBIPORÃ



## 8902 | Lanterna Lateral Diamond

Diamond Side Light | Luz Lateral Diamant

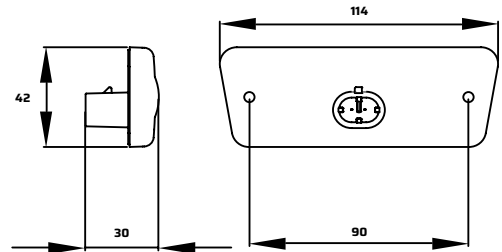

Código <i>Code - Código</i>	Tensão <i>Voltage - Voltaje</i>	Conexão <i>Connection - Conexión</i>	Fixação <i>Fixation - Fijación</i>	Funções <i>Functions - Funciones</i>	Observação <i>Observation - Observación</i>
8902.80.301	12/24V	Selada 2 Vias <i>2 Pin Sealed - Sellado de 2 Vías</i>	Frontal <i>Front - Frontal</i>	Posição   Retrorrefletor <i>Position Retroreflector</i> <i>Posición   Retrorreflector</i>	-
8902.80.305					

Original  
LIBRELATO



## 8582 | Lanterna Ponto de Luz

Light Point | Punto de Luz

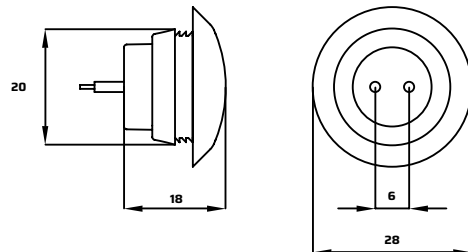

Código <i>Code - Código</i>	Tensão <i>Voltage - Voltaje</i>	Conexão <i>Connection - Conexión</i>	Fixação <i>Fixation - Fijación</i>	Funções <i>Functions - Funciones</i>	Observação <i>Observation - Observación</i>
8582.70.301	24V	Saída de fios <i>Wire Exit - Salida de Cables</i>	Embutir <i>Recessed - Empotrado</i>	Posição <i>Position - Posición</i>	Fios 280mm <i>280 mm Wires</i> <i>Cables de 280 mm</i>
8582.70.302					
8582.70.305					

Original  
CAIO



**8099 | Lanterna Delimitadora Ø89 mm**

Marker Light Ø89 mm | Luz Delimitadora Ø89 mm

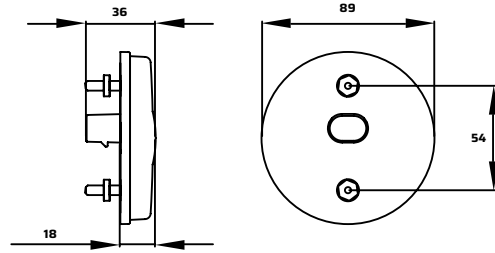

Código <i>Code - Código</i>	Tensão <i>Voltage - Voltaje</i>	Conexão <i>Connection - Conexión</i>	Fixação <i>Fixation - Fijación</i>	Funções <i>Functions - Funciones</i>	Observação <i>Observation - Observación</i>
8099.70.301	12/24V	Selado 2 Vias <i>2 Pin Sealed - Sellado de 2 Vias</i>	Traseira <i>Rear - Trasera</i>	Posição   Retrorrefletor <i>Position   Retrorreflector</i> <i>Posición   Retrorreflector</i>	
8099.70.302					
8099.70.304					
8099.70.305					
8099.G1.302					

Original

RANDON, LIBRELATO, GUERRA, NOMA, IBIPORÃ, TRUCKVAN

**8099 | Lanterna Delimitadora Ø 89mm com Suporte**

Marker Light Ø 89mm with Bracket | Luz Delimitadora Ø 89mm con Soporte

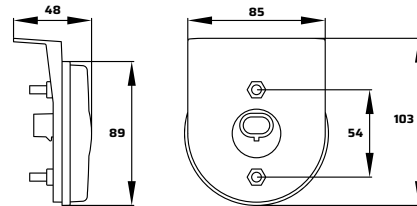

Código <i>Code - Código</i>	Tensão <i>Voltage - Voltaje</i>	Conexão <i>Connection - Conexión</i>	Fixação <i>Fixation - Fijación</i>	Funções <i>Functions - Funciones</i>	Observação <i>Observation - Observación</i>
8099.72.301	12/24V	Selado 2 Vias <i>2 Pin Sealed - Sellado de 2 Vias</i>	Superior <i>Upper - Superior</i>	Posição   Retro <i>Position   Retro - Posición   Retro</i>	
8099.72.302					
8099.72.305					

Original

RANDON, LIBRELATO, GUERRA, NOMA, IBIPORÃ, TRUCKVAN

**8929 | Lanterna Delimitadora Ø70 mm**

Marker Light Ø70 mm | Luz Delimitadora Ø70 mm

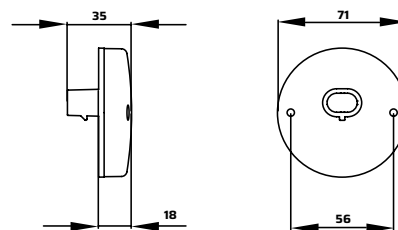
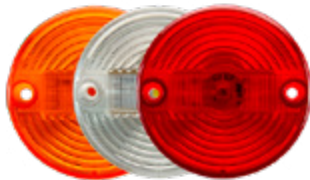

Código <i>Code - Código</i>	Tensão <i>Voltage - Voltaje</i>	Conexão <i>Connection - Conexión</i>	Fixação <i>Fixation - Fijación</i>	Funções <i>Functions - Funciones</i>	Observação <i>Observation - Observación</i>
8929.80.301	12 24V	Selado 2 Vias <i>2 Pin Sealed - Sellado de 2 Vias</i>	Traseira <i>Rear - Trasera</i>	Posição <i>Position - Posición</i>	
8929.80.302					
8929.80.305				Posição Dianteira <i>Front Position</i> <i>Posición Delantera</i>	

Original

MARCOPOLO, VOLARE



## 8540 | Lanterna Delimitadora Ø70 mm

Marker Light Ø70 mm | Luz Delimitadora Ø70 mm

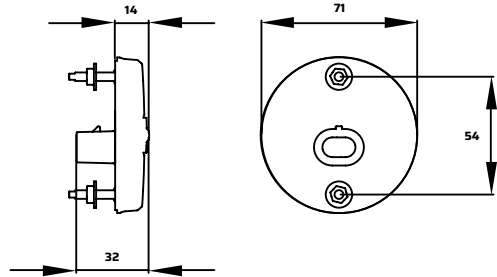
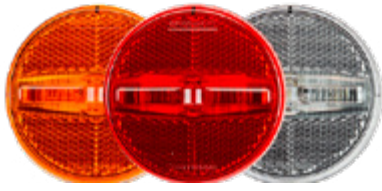

Código <i>Code - Código</i>	Tensão <i>Voltage - Voltaje</i>	Conexão <i>Connection - Conexión</i>	Fixação <i>Fixation - Fijación</i>	Funções <i>Functions - Funciones</i>	Observação <i>Observation - Observación</i>
■ 8540.81.301	12 24V	Selada 2 Vias <i>2 Pin Sealed - Sellado de 2 Vias</i>	Traseira <i>Rear - Trasera</i>	Posição   Retrorrefletor <i>Position   Retroreflector</i> Posición   Retrorreflector	-
■ 8540.81.302					
□ 8540.81.305					

Original  
LIBRELATO



## 8540 | Lanterna Delimitadora Ø 70mm com Suporte

Marker Light Ø 70mm with Bracket | Luz Delimitadora Ø 70mm con Soporte

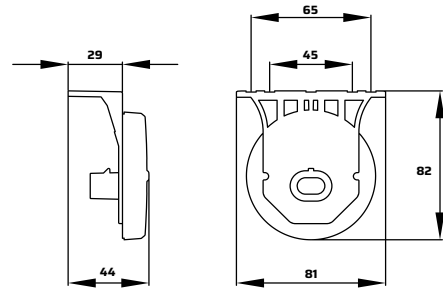

Código <i>Code - Código</i>	Tensão <i>Voltage - Voltaje</i>	Conexão <i>Connection - Conexión</i>	Fixação <i>Fixation - Fijación</i>	Funções <i>Functions - Funciones</i>	Observação <i>Observation - Observación</i>
■ 8540.83.301	12/24V	Selada 2 Vias <i>2 Pin Sealed - Sellado de 2 Vias</i>	Suporte <i>Bracket - Soporte</i>	Posição   Retro <i>Position   Retro - Posición   Retro</i>	-
■ 8540.83.302					

Original  
LIBRELATO



## 8064 | Lanterna Delimitadora Ø65 mm

Marker Light Ø65 mm | Luz Delimitadora Ø65 mm

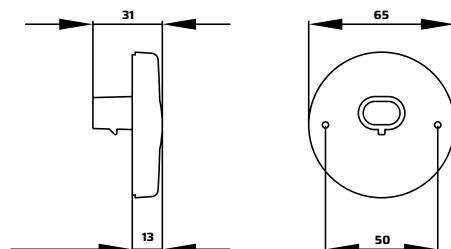

Código <i>Code - Código</i>	Tensão <i>Voltage - Voltaje</i>	Conexão <i>Connection - Conexión</i>	Fixação <i>Fixation - Fijación</i>	Funções <i>Functions - Funciones</i>	Observação <i>Observation - Observación</i>
■ 8064.85.301	12/24V	Selada 2 Vias <i>2 Pin Sealed - Sellado de 2 Vias</i>	Traseira <i>Rear - Trasera</i>	Posição   Retrorrefletor <i>Position Retroreflector</i> Posición   Retrorreflector	-
■ 8064.85.302					

Original  
RANDON



## 8064 | Lanterna Delimitadora Ø 65mm com Suporte

Marker Light Ø 65mm with Bracket | Luz Delimitadora Ø 65mm con Soporte

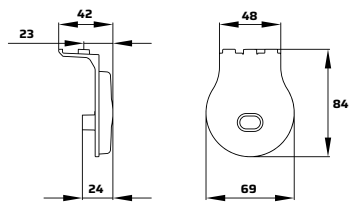

Código <i>Code - Código</i>	Tensão <i>Voltage - Voltaje</i>	Conexão <i>Connection - Conexión</i>	Fixação <i>Fixation - Fijación</i>	Funções <i>Functions - Funciones</i>	Observação <i>Observation - Observación</i>
8064.86.301	12/24V	Selado 2 Vias <i>2 Pin Sealed - Sellada de 2 Vias</i>	Suporte <i>Bracket - Soporte</i>	Posição   Retro <i>Position   Retro - Posición   Retro</i>	Fios 180mm <i>180mm Wires - Cables de 180mm</i>
8064.86.302					
8064.86.304					
8064.98.301					
8064.98.302					
8064.98.305					

Original  
RANDON



## 8064 | Lanterna Delimitadora Ø 65mm com Aba

Marker Light Ø 65mm with Flange | Luz Delimitadora Ø 65mm con Aleta

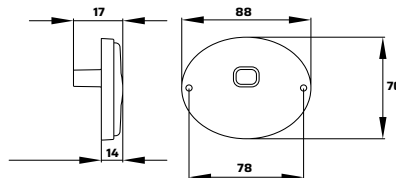

Código <i>Code - Código</i>	Tensão <i>Voltage - Voltaje</i>	Conexão <i>Connection - Conexión</i>	Fixação <i>Fixation - Fijación</i>	Funções <i>Functions - Funciones</i>	Observação <i>Observation - Observación</i>
8064.97.301	12/24V	Selado 2 Vias <i>2 Pin Sealed - Sellada de 2 Vias</i>	Suporte <i>Bracket - Soporte</i>	Posição   Retro <i>Position   Retro - Posición   Retro</i>	Fios 180mm <i>180mm Wires - Cables de 180mm</i>
8064.97.302					
8064.97.305					
8064.99.301		Saída de Fios <i>Wire Outlet - Salida de Cables</i>			
8064.99.302					
8064.99.305					

Original  
RANDON



## 8961 | Lanterna Delimitadora Quadrada C| Suporte

Square Marker Light W| Bracket | Luz Delimitadora Cuadrada C | Soporte

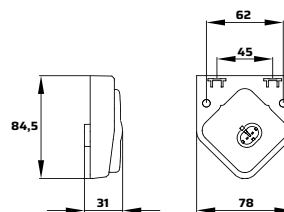

Código <i>Code - Código</i>	Tensão <i>Voltage - Voltaje</i>	Conexão <i>Connection - Conexión</i>	Fixação <i>Fixation - Fijación</i>	Funções <i>Functions - Funciones</i>	Observação <i>Observation - Observación</i>
8961.82.301	12/24V	Selado 2 Vias <i>2 Pin Sealed - Sellada de 2 Vias</i>	Suporte <i>Bracket - Soporte</i>	Posição   Retro <i>Position   Retro - Posición   Retro</i>	
8961.82.302					
8961.82.304					
8961.82.305					



## 8961 | Lanterna Delimitadora Quadrada

Square Marker Light | Luz Delimitadora Cuadrada

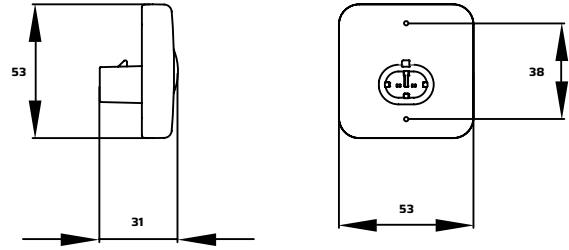

Código <i>Code - Código</i>	Tensão <i>Voltage - Voltaje</i>	Conexão <i>Connection - Conexión</i>	Fixação <i>Fixation - Fijación</i>	Funções <i>Functions - Funciones</i>	Observação <i>Observation - Observación</i>
■ 8961.80.301	12/24V	Selado 2 Vias 2 Pin Sealed - Sellado de 2 Vias	Traseira Rear - Trasera	Posição   Retrorefletor Position   Retroreflector Posición   Retroreflector	-
■ 8961.80.302					
□ 8961.80.305					

Original  
GUERRA



## 8961 | Lanterna Delimitadora Quadrada C| Suporte

Square Marker Light W| Bracket | Luz Delimitadora Cuadrada C | Soporte

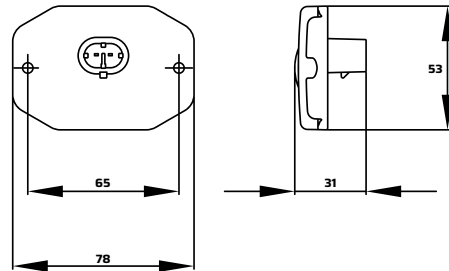

Código <i>Code - Código</i>	Tensão <i>Voltage - Voltaje</i>	Conexão <i>Connection - Conexión</i>	Fixação <i>Fixation - Fijación</i>	Funções <i>Functions - Funciones</i>	Observação <i>Observation - Observación</i>
■ 8961.88.301	12/24V	Selado 2 Vias 2 Pin Sealed - Sellado de 2 Vias	Suporte Bracket - Soporte	Posição   Retro Position   Retro - Posición   Retro	1 Lado Esquerdo 1 Left Side - 1 Lado Izquierdo
■ 8961.88.302					
□ 8961.88.305					
■ 8961.89.301	12/24V	Saída de fios Wire Outlet - Salida de Cables	Suporte Bracket - Soporte	Posição   Retro Position   Retro - Posición   Retro	Fios 300mm 300mm Wires - Cables de 300mm
■ 8961.89.304					
■ 8961.89.305					

Original  
GUERRA



## 8961 | Lanterna Delimitadora Quadrada C| Suporte

Square Marker Light W| Bracket | Luz Delimitadora Cuadrada C | Soporte

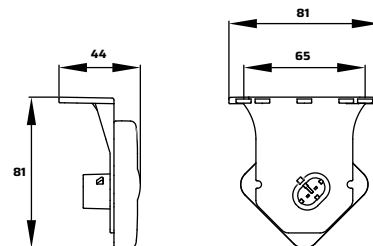

Código <i>Code - Código</i>	Tensão <i>Voltage - Voltaje</i>	Conexão <i>Connection - Conexión</i>	Fixação <i>Fixation - Fijación</i>	Funções <i>Functions - Funciones</i>	Observação <i>Observation - Observación</i>
■ 8961.87.301	12/24V	Selado 2 Vias 2 Pin Sealed - Sellado de 2 Vias	Suporte Bracket - Soporte	Posição   Retro Position   Retro - Posición   Retro	-
□ 8961.87.305					



## 8533 | Lanterna Delimitadora Central

Central Marker Light | Luz Del Límite Central

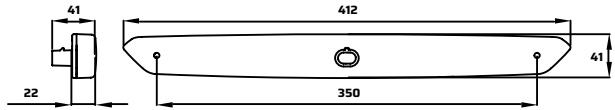

Código <i>Code - Código</i>	Tensão <i>Voltage - Voltaje</i>	Conexão <i>Connection - Conexión</i>	Fixação <i>Fixation - Fijación</i>	Funções <i>Functions - Funciones</i>	Observação <i>Observation - Observación</i>
8533.74.302	24V	Selada 2 Vias <i>2 Pin Sealed - Sellada de 2 Vias</i>	Frontal <i>Front - Frontal</i>	Posição <i>Position - Posición</i>	-

Original  
COMIL



## 8532 | Lanterna Delimitadora Dianteira

Frontal Marker Light | Luz Del Límite Delanteira

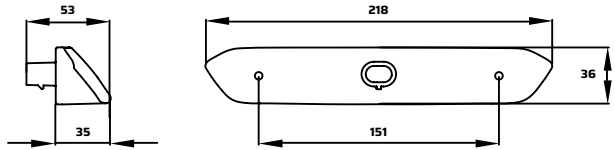

Código <i>Code - Código</i>	Tensão <i>Voltage - Voltaje</i>	Conexão <i>Connection - Conexión</i>	Fixação <i>Fixation - Fijación</i>	Funções <i>Functions - Funciones</i>	Observação <i>Observation - Observación</i>
8532.71.305	24V	Selada 2 Vias <i>2 Pin Sealed - Sellada de 2 Vias</i>	Frontal <i>Front - Frontal</i>	Posição Dianteira <i>Front Position - Posición Delanteira</i>	-

Original  
COMIL



## 8531 | Lanterna Delimitadora

Marker Light | Luz Del Límite

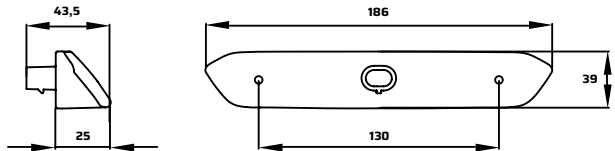

Código <i>Code - Código</i>	Tensão <i>Voltage - Voltaje</i>	Conexão <i>Connection - Conexión</i>	Fixação <i>Fixation - Fijación</i>	Funções <i>Functions - Funciones</i>	Observação <i>Observation - Observación</i>
8531.71.302	24V	Selada 2 Vias <i>2 Pin Sealed - Sellada de 2 Vias</i>	Frontal <i>Front - Frontal</i>	Posição <i>Position - Posición</i>	-

Original  
COMIL



## 8933 | Lanterna Delimitadora 4 Leds

4 Leds Marker Light | Luz Del Límite 4 Leds

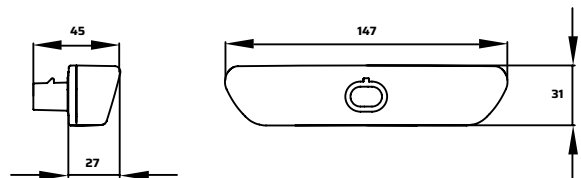

Código <i>Code - Código</i>	Tensão <i>Voltage - Voltaje</i>	Conexão <i>Connection - Conexión</i>	Fixação <i>Fixation - Fijación</i>	Funções <i>Functions - Funciones</i>	Observação <i>Observation - Observación</i>
8933.70.302	24V	Selada 2 Vias <i>2 Pin Sealed - Sellada de 2 Vias</i>	Embutir <i>Recessed - Empotrado</i>	Posição <i>Position - Posición</i>	-
8933.70.305				Posição Dianteira <i>Front Position - Posición Delanteira</i>	

Original  
MARCOPOLO



## 8951 | Lanterna Delimitadora

Boundary Light | Luz Del Límit

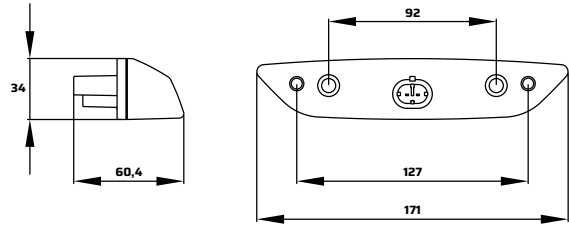

Código Code - Código	Tensão Voltage - Voltaje	Conexão Connection - Conexión	Fixação Fixation - Fijación	Funções Functions - Funciones	Observação Observation - Observación
<input checked="" type="checkbox"/> 8951.70.302	24V	Selada 2 Vias 2 Pin Sealed - Sellado de 2 Vias	Frontal Front - Frontal	Posição Position - Posición	-
<input type="checkbox"/> 8951.70.305				Posição Dianteira Front Position - Posición Delanteira	
<input type="checkbox"/> 8951.70.315				LED Âmbar	
<input checked="" type="checkbox"/> 8951.72.302			Traseira Rear - Trasera	Posição Position - Posición	-
<input type="checkbox"/> 8951.72.305				Posição Dianteira Front Position - Posición Delanteira	
<input type="checkbox"/> 8951.72.315				LED Âmbar	

Original  
MARCOPOLO, VOLARE



## 8956 | Lanterna Delimitadora

Marker Light | Luz Del Límite

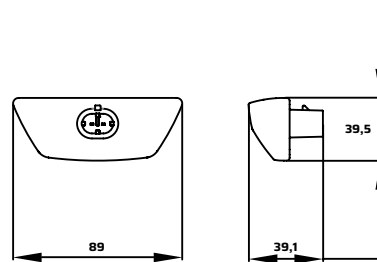

Código Code - Código	Tensão Voltage - Voltaje	Conexão Connection - Conexión	Fixação Fixation - Fijación	Funções Functions - Funciones	Observação Observation - Observación
<input checked="" type="checkbox"/> 8956.80.301	12/24v	Selada 2 Vias 2 Pin Sealed - Sellado de 2 Vias	Embutir Recessed - Empotrada	Posição Position - Posición	-
<input checked="" type="checkbox"/> 8956.80.302					
<input type="checkbox"/> 8956.80.305					

Original  
MARCOPOLO, VOLARE



## 8576 | Lanterna Delimitadora

Marker Light | Luz Del Límite

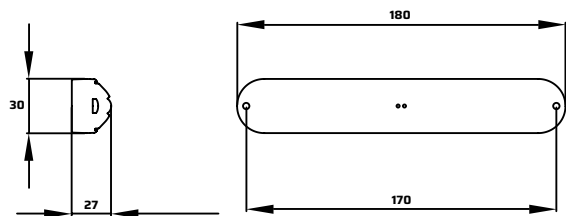

Código Code - Código	Tensão Voltage - Voltaje	Conexão Connection - Conexión	Fixação Fixation - Fijación	Funções Functions - Funciones	Observação Observation - Observación
<input checked="" type="checkbox"/> 8576.81.301	12/24V	2 term. faston c/ isolador 1 via 2 Faston Terminals with 1-Way Insulator 2 Terminales Faston con Aislador de 1 Via	Frontal Front - Frontal	Posição Position - Posición	-
<input checked="" type="checkbox"/> 8576.81.302				Posição Dianteira Front Position - Posición Delanteira	
<input type="checkbox"/> 8576.81.305				LED Âmbar	

Original  
MASCARELLO



## 8575 | Lanterna Delimitadora

Marker Light | Luz Del Límite

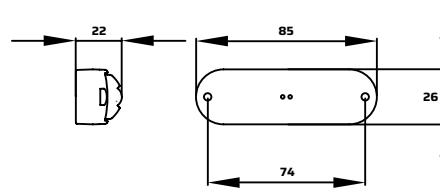

Código <i>Code - Código</i>	Tensão <i>Voltage - Voltaje</i>	Conexão <i>Connection - Conexión</i>	Fixação <i>Fixation - Fijación</i>	Funções <i>Functions - Funciones</i>	Observação <i>Observation - Observación</i>
8576.81.301	12/24V	2 terminais faston c isolador 1 via 2 Faston Terminals with 1-Way Insulator 2 Terminales Faston con Aislador de 1 Via	Frontal Front - Frontal	Posição Position - Posición	-
8576.81.302				Posição Dianteira Front Position - Posición Delantera	
8576.81.305					

Original  
MASCARELLO, COMIL, MAURO, SUL BRASIL



## 8998 | Lanterna Delimitadora

Marker Light | Luz Del Límite

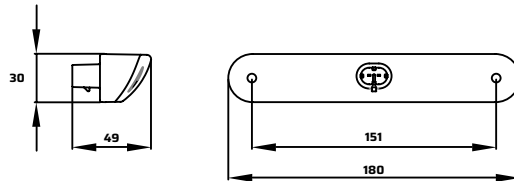

Código <i>Code - Código</i>	Tensão <i>Voltage - Voltaje</i>	Conexão <i>Connection - Conexión</i>	Fixação <i>Fixation - Fijación</i>	Funções <i>Functions - Funciones</i>	Observação <i>Observation - Observación</i>
8998.80.302	12/24V	Selada 2 Vias 2 Pin Sealed - Sellado de 2 Vias	Frontal Front - Frontal	Posição Position - Posición	-
8998.80.305					

Original  
CAIO



## 8999 | Lanterna Delimitadora

Marker Light | Luz Del Límite

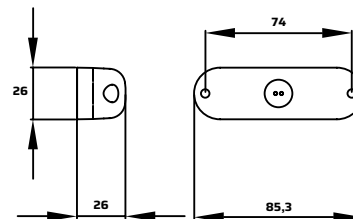

Código <i>Code - Código</i>	Tensão <i>Voltage - Voltaje</i>	Conexão <i>Connection - Conexión</i>	Fixação <i>Fixation - Fijación</i>	Funções <i>Functions - Funciones</i>	Observação <i>Observation - Observación</i>
8999.80.301	12/24V	2 terminais faston c isolador 1 via 2 Faston Terminals with 1-Way Insulator 2 Terminales Faston con Aislador de 1 Via	Frontal Front - Frontal	Posição Position - Posición	
8999.80.302					
8999.80.304					
8999.80.305					
8999.80.315					Led Âmbar Fios 360mm Led Âmbar 360 mm Wires Led Âmbar Cables de 360 mm

Original  
CAIO, MARCOPOLO, IRIZAR, COMIL



## 8999 | Lanterna Load Dump

Load Dump Light | Luz Load Dump

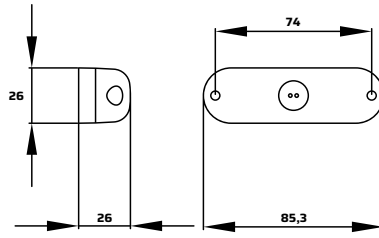

Código <i>Code - Código</i>	Tensão <i>Voltage - Voltaje</i>	Conexão <i>Connection - Conexión</i>	Fixação <i>Fixation - Fijación</i>	Funções <i>Functions - Funciones</i>	Observação <i>Observation - Observación</i>
8999.83.301	12/24V	2 Terminais Faston C/ Isolador 1 Via <i>2 Faston Terminals with Insulator 1 Way</i> 2 Terminales Faston con Aislador 1 Via	Frontal <i>Front - Frontal</i>	-	Fios 160mm <i>160mm Wires - Cables de 160mm</i>

Original  
MASCARELLO



## 8999 | Lanterna Delimitadora 6 LED's

6 Led's Marker Light | Luz Delimitadora 6 Led's

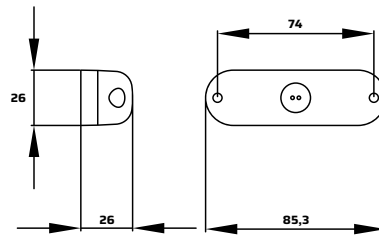

Código <i>Code - Código</i>	Tensão <i>Voltage - Voltaje</i>	Conexão <i>Connection - Conexión</i>	Fixação <i>Fixation - Fijación</i>	Funções <i>Functions - Funciones</i>	Observação <i>Observation - Observación</i>
8999.89.305	12/24V	Selada 2 Vias <i>2 Pin Sealed - Sellado de 2 Vias</i>	Frontal <i>Front - Frontal</i>	Posição <i>Position - Posición</i>	-



## 8996 | Lanterna Delimitadora

Marker Light | Luz Del Límite

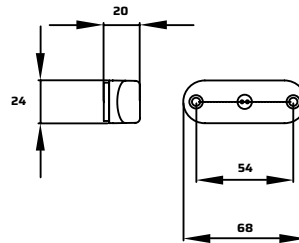
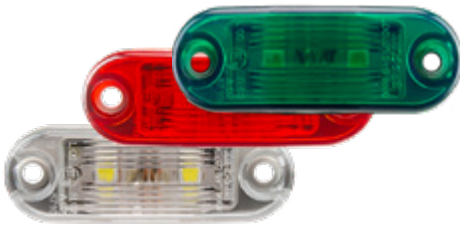

Código <i>Code - Código</i>	Tensão <i>Voltage - Voltaje</i>	Conexão <i>Connection - Conexión</i>	Fixação <i>Fixation - Fijación</i>	Funções <i>Functions - Funciones</i>	Observação <i>Observation - Observación</i>
8996.80.301	12/24V	2 terminais faston c isolador 1 via <i>2 Faston Terminals with 1-Way Insulator</i> 2 Terminales Faston con Aislador de 1 Via	Frontal <i>Front - Frontal</i>	Posição <i>Position - Posición</i>	Fios 180mm <i>180 mm Wires - Cables de 180 mm</i>
8996.80.302					
8996.80.304					
8996.80.305		Selada 2 Vias <i>2 Pin Sealed - Sellado de 2 Vias</i>			-
8996.81.301					
8996.81.302					
8996.81.304					
8996.81.305					
8996.57.304					

Original  
RANDON, IBIPORÁ, LIBRELATO, TRICKVAN, FURGÕES JOINVILLE, GUERRA, NOMA, MARCOPOLO, MASCARELLO



## 8539 | Lanterna Delimitadora

Marker Light | Luz Delimitadora

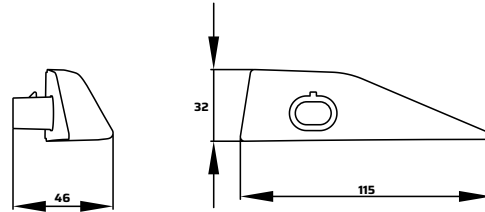

Código <i>Code - Código</i>	Tensão <i>Voltage - Voltaje</i>	Conexão <i>Connection - Conexión</i>	Fixação <i>Fixation - Fijación</i>	Funções <i>Functions - Funciones</i>	Observação <i>Observation - Observación</i>
■ 8539.80.302	12/24V	Selado 2 Vias <i>2 Pin Sealed - Sellado de 2 Vias</i>	Embutir <i>Recessed - Empotrar</i>	Posição <i>Position - Posición</i>	Lado Direito <i>Right Side - Lado Derecho</i>
■ 8539.81.302					Lado Esquerdo <i>Left Side - Lado Izquierdo</i>

Original  
MARCOPOLO



## 8567 | Lanterna Delimitadora

Marker Light | Luz Delimitadora

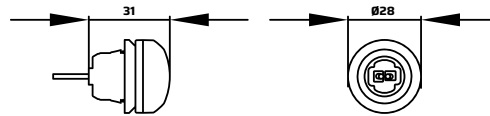

Código <i>Code - Código</i>	Tensão <i>Voltage - Voltaje</i>	Conexão <i>Connection - Conexión</i>	Fixação <i>Fixation - Fijación</i>	Funções <i>Functions - Funciones</i>	Observação <i>Observation - Observación</i>
8567.71.302	24V	Saída de fios <i>Wire Outlet - Salida de Cables</i>	Embutir <i>Recessed - Empotrar</i>	Posição <i>Position - Posición</i>	Fios 180mm <i>180mm Wires - Cables de 180mm</i>
8567.71.305					

Original  
BUSSCAR



## 8571 | Lanterna 2" com Flange

2" Light with Flange | Luz 2" com gama

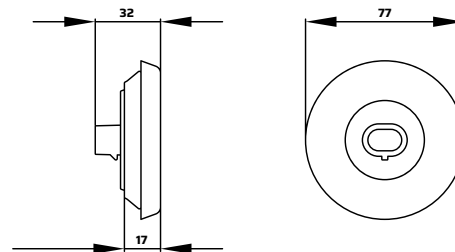

Código <i>Code - Código</i>	Tensão <i>Voltage - Voltaje</i>	Conexão <i>Connection - Conexión</i>	Fixação <i>Fixation - Fijación</i>	Funções <i>Functions - Funciones</i>	Observação <i>Observation - Observación</i>
■ 8571.80.301	12/24V	Saída de fios <i>Wire Outlet - Salida de Cables</i>	Embutir <i>Recessed - Empotrar</i>	Posição <i>Position - Posición</i>	
■ 8571.80.302					
□ 8571.80.305					

Original  
ROSSETI



## 8953 | Lanterna Delimitadora

Marker Light | Luz Delimitadora

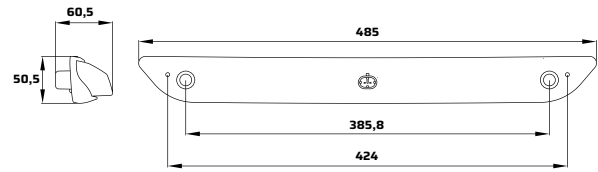
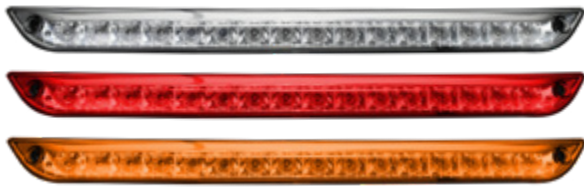

Código <i>Code - Código</i>	Tensão <i>Voltage - Voltaje</i>	Conexão <i>Connection - Conexión</i>	Fixação <i>Fixation - Fijación</i>	Funções <i>Functions - Funciones</i>	Observação <i>Observation - Observación</i>
 8953.70.301	24V	Selado 2 Vias <i>2 Pin Sealed - Sellado de 2 Vias</i>	Frontal <i>Front - Frontal</i>	Posição <i>Position - Posición</i>	-
 8953.70.302					
 8953.70.305					

Original  
MARCOPOLO



## 8957 | Lanterna Cortesia

Courtesy Light | Luz de Cortesia

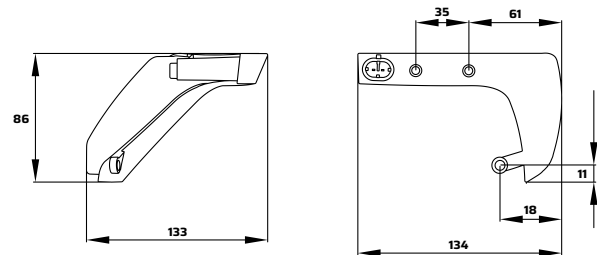

Direito <i>Right - Derecha</i>	Esquerdo <i>Left - Izquierda</i>	Tensão <i>Voltage - Voltaje</i>	Conexão <i>Connection - Conexión</i>	Fixação <i>Fixation - Fijación</i>	Funções <i>Functions - Funciones</i>	Observação <i>Observation - Observación</i>
8957.70.305	8957.71.305	24V	Selado 2 Vias <i>2 Pin Sealed - Sellado de 2 Vias</i>	Traseira <i>Rear - Trasera</i>	Posição <i>Position - Posición</i>	Fios 1500mm <i>1500 mm Wires Cables de 1500 mm</i>



Original  
COMIL

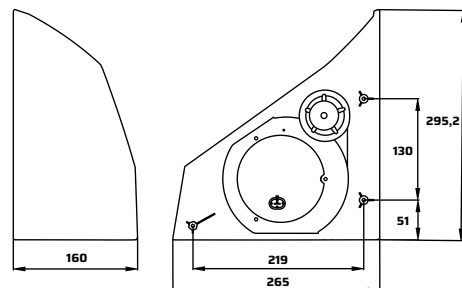

## 8960 | Lanterna Dianteira Direcional

Front Directional Light | Luz Direccional Delantera



Direito <i>Right - Derecha</i>	Esquerdo <i>Left - Izquierda</i>	Tensão <i>Voltage - Voltaje</i>	Conexão <i>Connection - Conexión</i>	Fixação <i>Fixation - Fijación</i>	Funções <i>Functions - Funciones</i>	Observação <i>Observation - Observación</i>
 8960.LD.301	8960.LE.301	24V	Selado 2 Vias <i>2 Pin Sealed - Sellado de 2 Vias</i>	Frontal <i>Front - Frontal</i>	Posição Dianteira <i>Front Position - Posición Delantera</i>	-
 8960.LD.306	8960.LE.306					

Original  
AGRALE



## 8958 | Lanterna Duto de Luz

Duct Light | Conducto de Luz

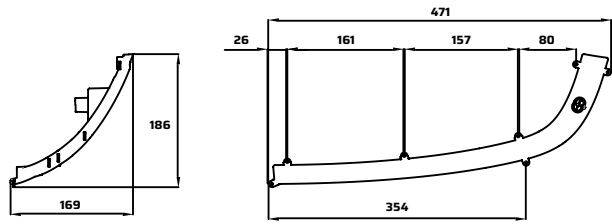

Direito Code - Código	Esquerdo Voltage - Voltaje	Tensão Voltage - Voltaje	Conexão Connection - Conexión	Fixação Fixation - Fijación	Funções Functions - Funciones	Observação Observation - Observación
8958.70.302	8958.71.302	24V	Selada 2 Vias 2 Pin Sealed - Sellado de 2 Vias	Frontal Front - Frontal	Posição Position - Posición	-

Original  
COMIL



## 8955 | Lanterna Delimitadora

Marker Light | Luz Delimitadora

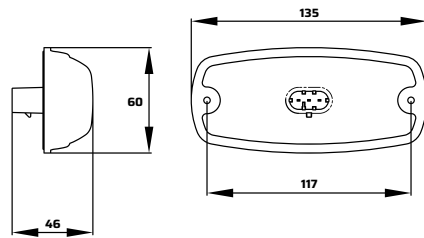

Código Code - Código	Tensão Voltage - Voltaje	Conexão Connection - Conexión	Fixação Fixation - Fijación	Funções Functions - Funciones	Observação Observation - Observación
8955.84.301	24V	Selado 3 Vias 3 Pin Sealed - Sellado de 3 Vias	Frontal Front - Frontal	Posição   Direcional   Retro Position   Turn Signal   Reflector Posición   Direccional   Retroreflector	Fios 180mm 180mm Wires - Cables de 180mm

Original  
MARCOPOLO



## 8987 | Lanterna Espelho

Mirror Light | Luz Espejo

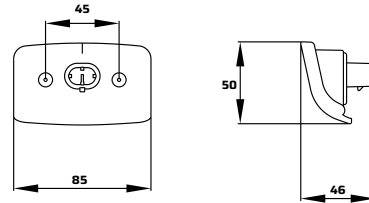

Código Code - Código	Tensão Voltage - Voltaje	Conexão Connection - Conexión	Fixação Fixation - Fijación	Funções Functions - Funciones	Observação Observation - Observación
8987.80.301	12/24V	Selado 2 Vias 2 Pin Sealed - Sellado de 2 Vias	Traseira Rear - Trasera	-	-



## 8146 | Lanterna Delimitadora Difusa

Diffuse Marker Light | Luz delimitadora difusa

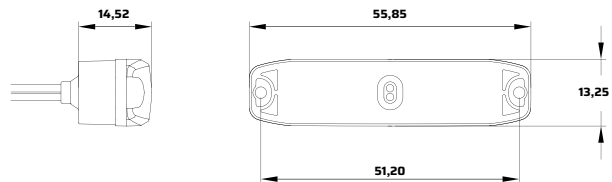

Código Code - Código	Tensão Voltage - Voltaje	Conexão Connection - Conexión	Fixação Fixation - Fijación	Funções Functions - Funciones	Observação Observation - Observación
8146.80.302	12/24V	Saída de fios Wire Output - Salida de cables	Frontal Front - Frontal	Posição Traseira Rear Position - Posición trasera	-
8146.80.305				Posição	Potência Posição 0.47/1.03W Position Power   Potencia de posición
8146.80.315				Posição	Potência Posição 0.57/1.23W Position Power   Potencia de posición



## 8991 | Lanterna Delimitadora

Marker Light | Luz Delimitadora

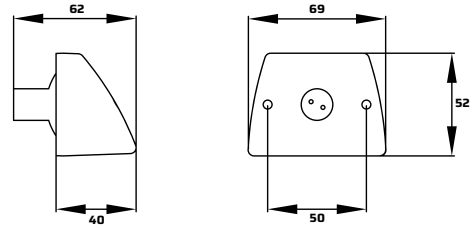

Código <i>Code - Código</i>	Tensão <i>Voltage - Voltaje</i>	Conexão <i>Connection - Conexión</i>	Fixação <i>Fixation - Fijación</i>	Funções <i>Functions - Funciones</i>	Observação <i>Observation - Observación</i>
■ 8991.80.302	12/24V	Saída de fios <i>Wire Outlet - Salida de Cables</i>	Frontal <i>Front - Frontal</i>	Posição <i>Position - Posición</i>	Fios 180mm <i>180mm Wires - Cables de 180mm</i>
□ 8991.80.305		-			

Original  
COMIL



## 8971 | Lanterna Delimitadora

Marker Light | Luz Delimitadora

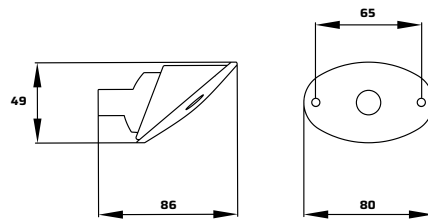
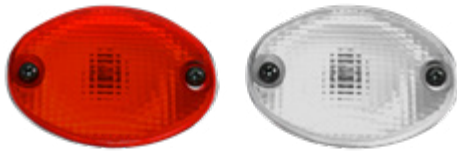

Código <i>Code - Código</i>	Tensão <i>Voltage - Voltaje</i>	Conexão <i>Connection - Conexión</i>	Fixação <i>Fixation - Fijación</i>	Funções <i>Functions - Funciones</i>	Observação <i>Observation - Observación</i>
■ 8971.80.302	12/24V	Saída de fios <i>Wire Outlet - Salida de Cables</i>	Frontal <i>Front - Frontal</i>	Posição <i>Position - Posición</i>	Fios 180mm <i>180mm Wires - Cables de 180mm</i>
□ 8971.80.305		-			

Original  
COMIL



## 8989 | Lanterna Delimitadora

Marker Light | Luz Delimitadora

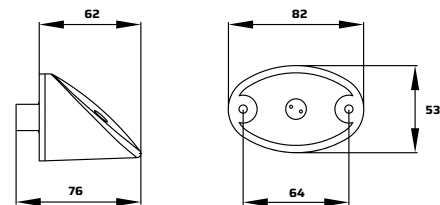

Código <i>Code - Código</i>	Tensão <i>Voltage - Voltaje</i>	Conexão <i>Connection - Conexión</i>	Fixação <i>Fixation - Fijación</i>	Funções <i>Functions - Funciones</i>	Observação <i>Observation - Observación</i>
□ 8989.80.305	12/24V	Saída de fios <i>Wire Outlet - Salida de Cables</i>	Frontal <i>Front - Frontal</i>	Posição <i>Position - Posición</i>	Fios 180mm <i>180mm Wires - Cables de 180mm</i>

Original  
COMIL



## 8152 | Lanterna Delimitadora Difusa

Diffuse Marker Light | Luz delimitadora difusa

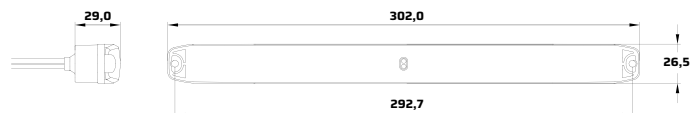
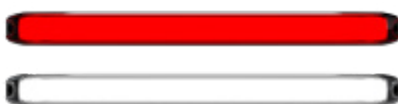

Código <i>Code - Código</i>	Tensão <i>Voltage - Voltaje</i>	Conexão <i>Connection - Conexión</i>	Fixação <i>Fixation - Fijación</i>	Funções <i>Functions - Funciones</i>	Observação <i>Observation - Observación</i>
■ 8152.80.302	12/24V	Saída de fios <i>Wire Outlet - Salida de Cables</i>	Frontal <i>Front - Frontal</i>	Posição Traseira <i>Rear Position - Posición trasera</i>	-
□ 8152.80.305					



## 8054 | Lanterna Delimitadora

Marker Light | Luz Delimitadora

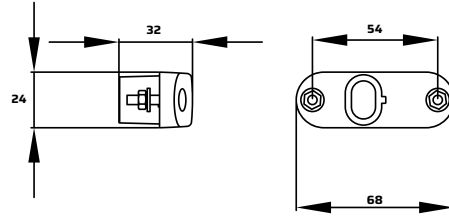

Código <i>Code - Código</i>	Tensão <i>Voltage - Voltaje</i>	Conexão <i>Connection - Conexión</i>	Fixação <i>Fixation - Fijación</i>	Funções <i>Functions - Funciones</i>	Observação <i>Observation - Observación</i>
8054.71.304	12/24V	Selado 2 Vias <i>2 Pin Sealed - Sellada de 2 Vias</i>	Traseira <i>Rear - Trasera</i>	-	-



## 8962 | Acabamento Conjunto Lanterna Duct Wide

Finishing Set Lantern Duct Wide | Acabado Conjunto Luz Duct Wide

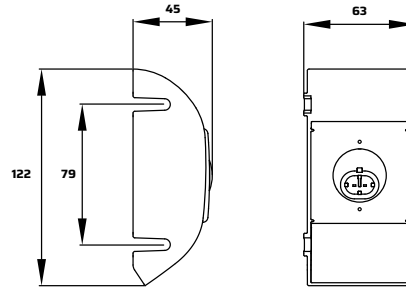

Código <i>Code - Código</i>	Tensão <i>Voltage - Voltaje</i>	Conexão <i>Connection - Conexión</i>	Fixação <i>Fixation - Fijación</i>	Funções <i>Functions - Funciones</i>	Observação <i>Observation - Observación</i>
8962.00.000	12/24V	Selado 2 Vias <i>2 Pin Sealed - Sellada de 2 Vias</i>	Suporte <i>Support - soporte</i>	Posição   Retro <i>Position   Reflector</i> Posición   Retreflector	-



## 8113 | Lanterna Dianteira Pulverizador Direcional

Front Sprayer Directional light | Luz Delantera Pulverizador Direccional

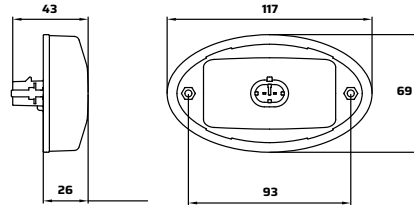

Código <i>Code - Código</i>	Tensão <i>Voltage - Voltaje</i>	Conexão <i>Connection - Conexión</i>	Fixação <i>Fixation - Fijación</i>	Funções <i>Functions - Funciones</i>	Observação <i>Observation - Observación</i>
8113.60.315	12V	Selado 2 Vias <i>2 Pin Sealed - Sellada de 2 Vias</i>	Traseira <i>Rear - Trasera</i>	Direcional <i>Turn Signal - Direccional</i>	-



## 8145 | Lanterna Delimitadora Linnea

Linnea Marker Light | Luz Delimitadora Linnea

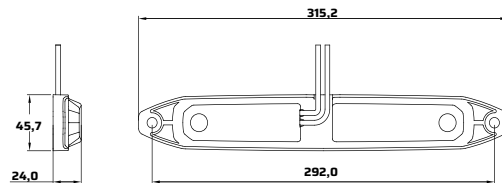

Código <i>Code - Código</i>	Tensão <i>Voltage - Voltaje</i>	Conexão <i>Connection - Conexión</i>	Fixação <i>Fixation - Fijación</i>	Funções <i>Functions - Funciones</i>	Observação <i>Observation - Observación</i>
8145.70.305	24V	Saída de fios <i>2 Pin Sealed - Sellada de 2 Vias</i>	Frontal <i>Front - Frontal</i>	Posição   Retro <i>Position - Posición</i>	-
8145.71.305				Posição   Direccional <i>Position   Turn Signal</i> Posición   Direccional	



# Retrorefletores

---

Com alta taxa de retroreflexão, atendem de forma plana as exigências normativas garantindo segurança e visibilidade.

## **Retroreflectors**

*High retroreflection rate fully meets regulatory requirements ensuring safety and visibility.*

## **Retroreflectores**

*Con alta tasa de retroreflexión, cumplen plenamente con las exigencias normativas garantizando seguridad y visibilidad.*



### 8021 | Retrorrefletor Triangular

Triangular Retroreflector | Retrorreflector Triangular

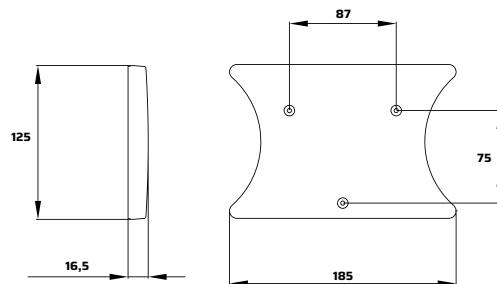

Código <i>Code - Código</i>	Fixação <i>Fixation - Fijación</i>
8021.00.302	Traseira <i>Rear - Trasera</i>

Original  
RANDON



### 8025 | Retrorrefletor Triangular

Triangular Retroreflector | Retrorreflector Triangular

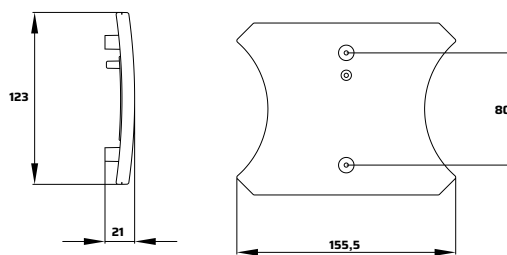

Código <i>Code - Código</i>	Fixação <i>Fixation - Fijación</i>
8025.00.302	Traseira <i>Rear - Trasera</i>

Original  
LIBRELATO



### 8185 | Retrorrefletor

Retroreflector | Retrorreflector

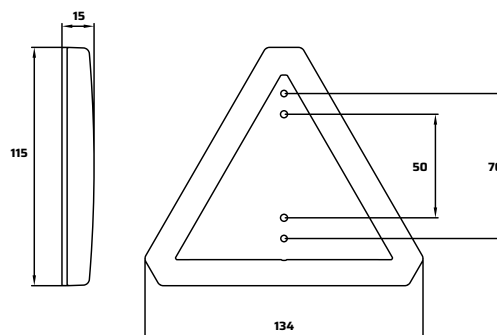
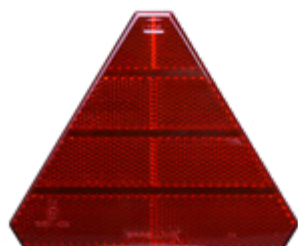

Código <i>Code - Código</i>	Fixação <i>Fixation - Fijación</i>	Observação <i>Observation - Observación</i>
8185.00.302	Traseira <i>Rear - Trasera</i>	Sem Prisioneiro <i>Without Nut - Sin Tuerca</i>
8185.01.302		Com Prisioneiro <i>With Nut - Con Tuerca</i>

Original  
USICAMP, IBIPORA, FURGÕES JOINVILE, SUL BRASIL, ESTRADA, NOSTRA, MAUTO TÓIA.



**8076 | Retrorrefletor**

Retroreflector | Retrorreflector

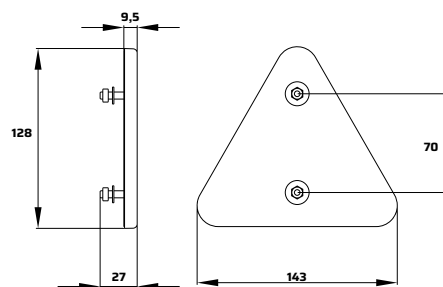

Código <i>Code - Código</i>	Fixação <i>Fixation - Fijación</i>	Observação <i>Observation - Observación</i>
8076.00.302	Traseira <i>Rear - Trasera</i>	Com Porca <i>With Nut - Con Tuerca</i>
8076.01.302		Sem Porca <i>Without Nut - Sin Tuerca</i>

Original

NOMA, LIBRELATO, GUERRA, ROSSETI, SERGOMEL

**8519 | Retrorrefletor**

Triangular | Retrorreflector

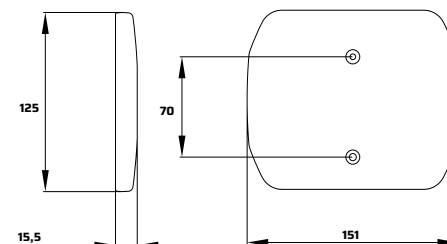

Código <i>Code - Código</i>	Fixação <i>Fixation - Fijación</i>
8519.00.302	Traseira <i>Rear - Trasera</i>

Original

LIBRELATO, TRUCKVAN

**8528 | Retrorrefletor**

Retroreflector | Retrorreflector

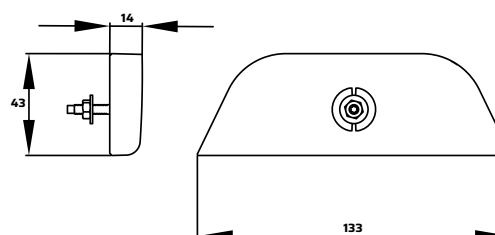

Código <i>Code - Código</i>	Fixação <i>Fixation - Fijación</i>
8528.00.302	Traseira <i>Rear - Trasera</i>

Original

MARCOPOLO



## 8903 | Retrorrefletor

Retroreflector | Retroreflector

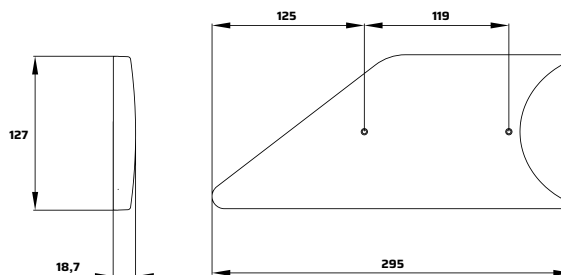
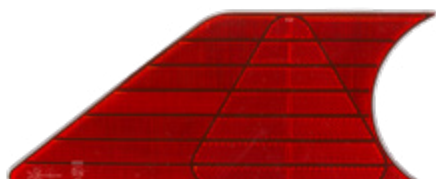

Direito <i>Right - Derecha</i>	Esquerdo <i>Left - Izquierda</i>	Fixação <i>Fixation - Fijación</i>
8903.10.302	8903.11.302	Traseira <i>Rear - Trasera</i>

Original  
RANDON



## 8539 | Retrorrefletor Triangular

Triangular Retroreflector | Retroreflector Triangular

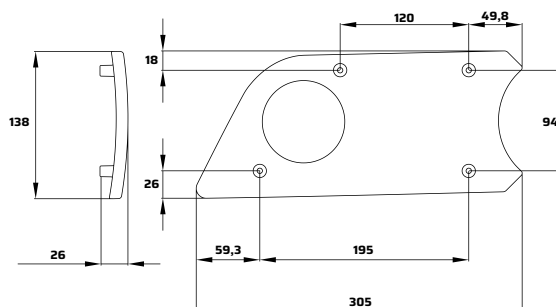

Direito <i>Right - Derecha</i>	Esquerdo <i>Left - Izquierda</i>	Fixação <i>Fixation - Fijación</i>
8939.00.302	8939.01.302	Traseira <i>Rear - Trasera</i>

Original  
LIBRELATO



## 8983 | Retrorrefletor

Retroreflector | Retroreflector

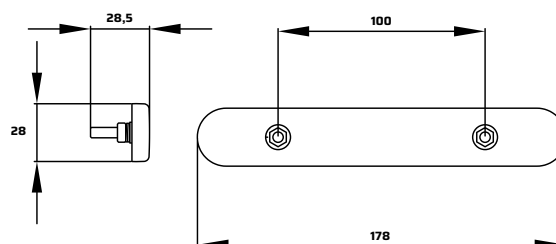
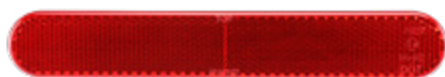

Código <i>Code - Código</i>	Fixação <i>Fixation - Fijación</i>
8983.00.302	Traseira <i>Rear - Trasera</i>

Original  
MASCARELLO, IRIZAR



**8981 | Retrorrefletor Ø 60mm**

Ø 60mm Retroreflector | Retrorreflector Ø 60mm

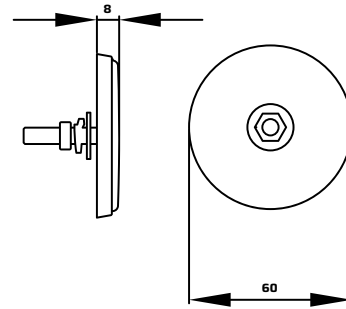

Código Code - Código		Fixação Fixation - Fijación	Observação Observation - Observación
■	8981.00.301	Traseira Rear - Trasera	Com Parafuso M6X16 With M6X16 Screw - Con Tornillo M6X16
■	8981.00.302		
□	8981.00.305		
■	8981.20.301		Com Parafuso M6X30 With M6X30 Screw - Con Tornillo M6X30
■	8981.20.302		
□	8981.20.305		
■	8981.21.302		Com Porca auto frenante With Self-Locking Nut - Con Tuerca Autofrenante

Original

DYNAPAC, IMPLMASTER, BEPO, NEOBUS, MARCOPOLO

**8043 | Retrorrefletor Ø 84mm**

Ø 84mm Retroreflector | Retrorreflector Ø 84mm

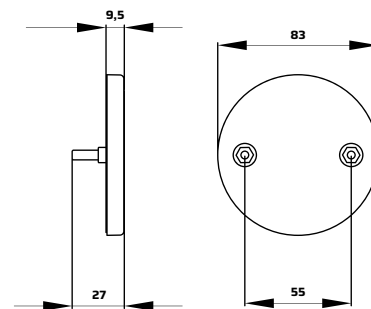
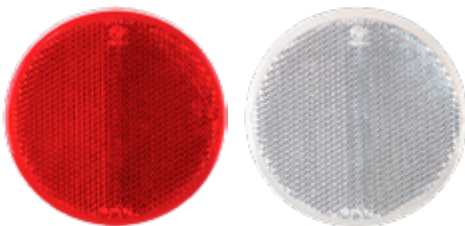

Código Code - Código		Fixação Fixation - Fijación
■	8043.00.302	Traseira Rear - Trasera
□	8043.00.305	

Original

MARCOPOLO, MASCARELLO



# Iluminação geral

---

A mais alta tecnologia, durabilidade e eficiência que você só encontra nas lanternas originais Braslux.

## **General Lighting**

*Wide range solutions for various applications, with high efficiency and reliability.*

## **Iluminación general**

*Amplia gama de soluciones para las más diversas aplicaciones, con alto grado de eficiencia y confiabilidad.*



## 8083 | Lanterna Interna Lumi Slim

Interior Slim Light | Lumi Slim

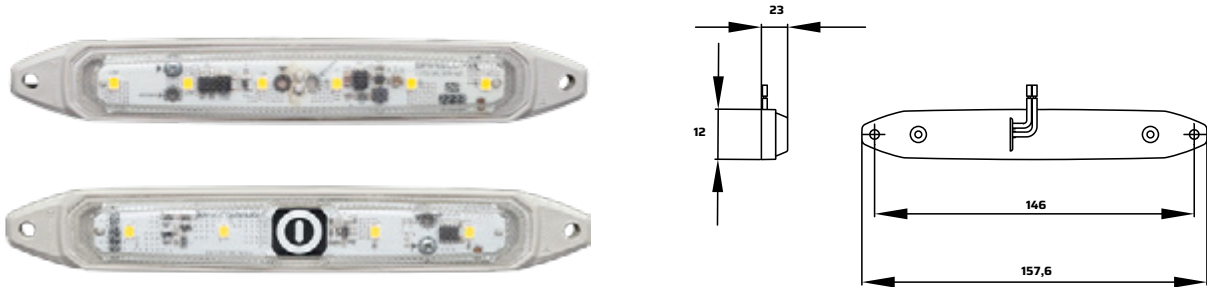

Código <i>Code - Código</i>	Tensão <i>Voltage - Voltaje</i>	Conexão <i>Connection - Conexión</i>	Fixação <i>Fixation - Fijación</i>	Observação <i>Observation - Observación</i>
8083.80.305	12/24V	Saída de Fios <i>Wire Outlet - Salida de Cables</i>	Frontal <i>Front - Frontal</i>	Fios 180mm   Com touch <i>180 mm Wires   With Touch Cables de 180 mm   Con Touch</i>
8083.81.305				Fios 180mm <i>180 mm Wires - Cables de 180 mm</i>
8083.82.305				Fios 1500mm p/ Carcaça 10mm <i>1500 mm Wires for 10 mm Housing Cables de 1500 mm para Carcasa de 10 mm</i>



## 8562 | Giroflex Slim

Slim Beacon | Licuador Slim

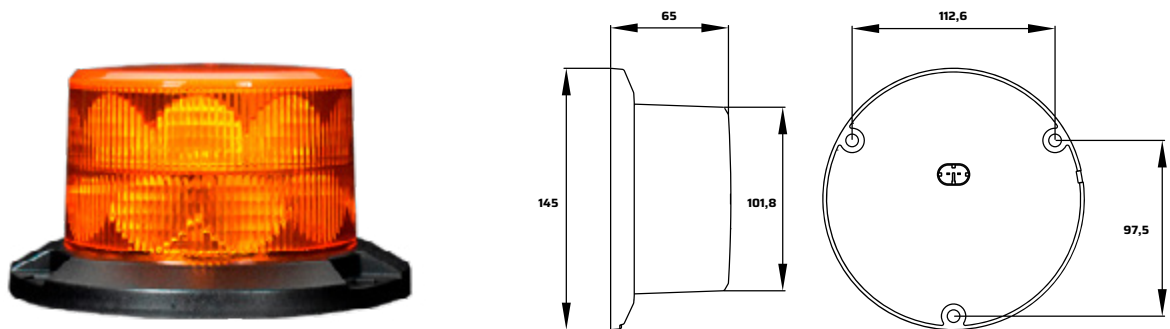

Código <i>Code - Código</i>	Tensão <i>Voltage - Voltaje</i>	Conexão <i>Connection - Conexión</i>	Fixação <i>Fixation - Fijación</i>	Observação <i>Observation - Observación</i>
8562.80.201	12/24V	Selada 2 Vias <i>2 Pin Sealed - Sellada de 2 Vias</i>	Frontal <i>Front - Frontal</i>	-
8562.81.201		Saquete ISO 4165 <i>ISO 4165 Socket Enchufe ISO 4165</i>		Com base <i>With Base - Con Base</i>
8562.82.201		Selada 2 Vias <i>2 Pin Sealed - Sellada de 2 Vias</i>		



## 8521 | Compacto

Compact Beacon | Licuador Compacto

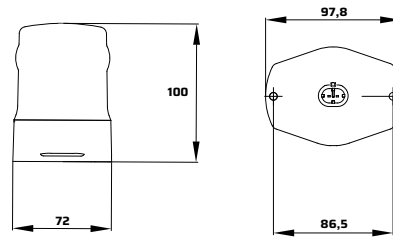

Código <i>Code - Código</i>	Tensão <i>Voltage - Voltaje</i>	Conexão <i>Connection - Conexión</i>	Fixação <i>Fixation - Fijación</i>	Observação <i>Observation - Observación</i>
8521.80.301	12/24V	Selada 2 Vias <i>2 Pin Sealed - Sellado de 2 Vias</i>	Frontal <i>Front - Frontal</i>	-



## 8037 | Lanterna Interna Dicroica Elíptica

Elliptical Dichroic Indoor Light | Luz Interna Dicroica Elíptica

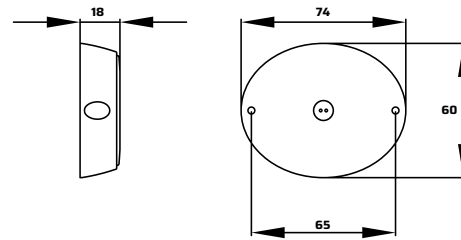

Código <i>Code - Código</i>	Tensão <i>Voltage - Voltaje</i>	Conexão <i>Connection - Conexión</i>	Fixação <i>Fixation - Fijación</i>	Observação <i>Observation - Observación</i>
8037.82.305	12/24V	Terminal Faston Com Isolador 2 Vias <i>Faston Terminal with Insulator, 2-Way</i> <i>Terminal Faston con Aislador, 2 Vias</i>	Frontal <i>Front - Frontal</i>	Fios 180mm <i>180 mm Wires - Cables de 180 mm</i>



## 8544 | Lanterna de Teto Touch

Touch Roof Light | Luz de Techo Touch

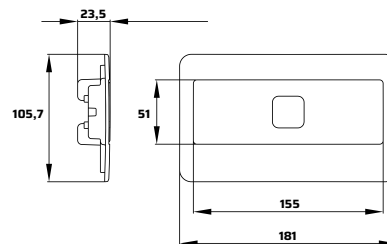

Código <i>Code - Código</i>	Tensão <i>Voltage - Voltaje</i>	Conexão <i>Connection - Conexión</i>	Fixação <i>Fixation - Fijación</i>	Observação <i>Observation - Observación</i>
8544.80.305	12/24V	Terminal Faston Com Isolador 4 Vias <i>Faston Terminal with Insulator, 4-Way</i> <i>Terminal Faston con Aislador, 4 Vias</i>	Embutir <i>Recessed - Empotrado</i>	-

Original  
AGCO



## 8181 | Lanterna de Placa

Registration Plate Light | Luz de Placa

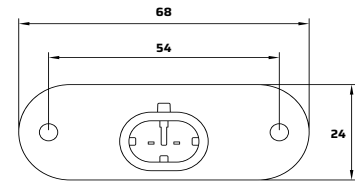
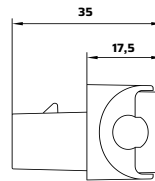

Código <i>Code - Código</i>	Tensão <i>Voltage - Voltaje</i>	Conexão <i>Connection - Conexión</i>	Fixação <i>Fixation - Fijación</i>	Observação <i>Observation - Observación</i>
8181.80.305	12/24V	Selada 2 Vias <i>2 Pin Sealed - Sellado de 2 Vias</i>	Frontal <i>Front - Frontal</i>	-



## 8055 | Lanterna de Placa

Registration Plate Light | Luz de Placa

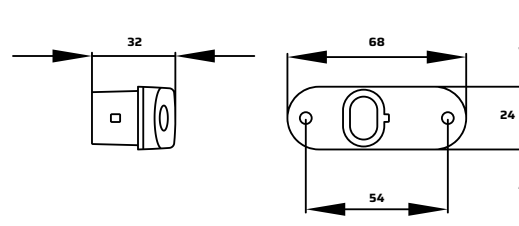

Código <i>Code - Código</i>	Tensão <i>Voltage - Voltaje</i>	Conexão <i>Connection - Conexión</i>	Fixação <i>Fixation - Fijación</i>	Observação <i>Observation - Observación</i>
8055.70.305	24V	Selada 2 Vias <i>2 Pin Sealed - Sellado de 2 Vias</i>	Frontal <i>Front - Frontal</i>	-

Original  
CAIO



## 8002 | Lanterna de Placa

Plate Light | Luz de Placa

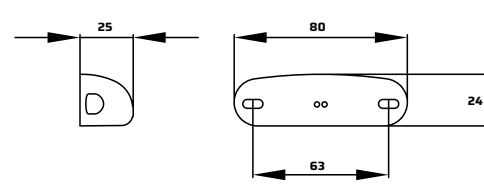

Código <i>Code - Código</i>	Tensão <i>Voltage - Voltaje</i>	Conexão <i>Connection - Conexión</i>	Fixação <i>Fixation - Fijación</i>	Observação <i>Observation - Observación</i>
8002.83.305	12/24V	Saídas de Fios <i>Wire Outputs - Salidas de Cables</i>	Frontal <i>Front - Frontal</i>	-



## 8059 | Lanterna de Placa 90°

90° Plate Light | Luz de Placa 90°

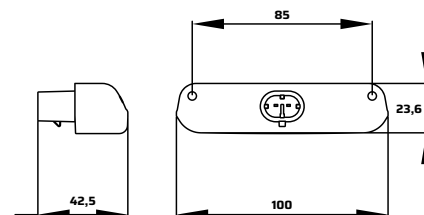

Código <i>Code - Código</i>	Tensão <i>Voltage - Voltaje</i>	Conexão <i>Connection - Conexión</i>	Fixação <i>Fixation - Fijación</i>	Observação <i>Observation - Observación</i>
8059.80.305	12/24V	Selada 2 Vias <i>2 Pin Sealed - Sellado de 2 Vias</i>	Frontal <i>Front - Frontal</i>	-

Original  
RANDON, LIBRELATO, GUERRA, NOMA



### 8011 | Lanterna de Porta

Door Light | Linterna de porta

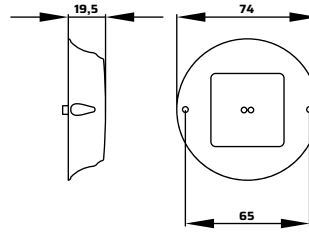

Código <i>Code - Código</i>	Tensão <i>Voltage - Voltaje</i>	Conexão <i>Connection - Conexión</i>	Fixação <i>Fixation - Fijación</i>	Observação <i>Observation - Observación</i>
8011.24.001	12/24V	Saídas de Fios <i>Wire Outputs - Salidas de Cables</i>	Frontal <i>Front - Frontal</i>	Fio 250mm <i>250mm Wire - Cables 250mm</i>



### 8029 | Lanterna de Degrau

Step Light | Luz de Degrau

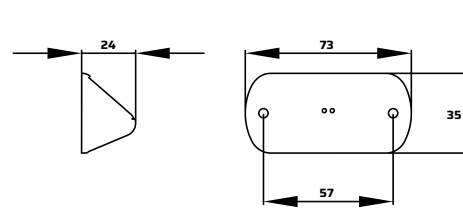

Código <i>Code - Código</i>	Tensão <i>Voltage - Voltaje</i>	Conexão <i>Connection - Conexión</i>	Fixação <i>Fixation - Fijación</i>	Observação <i>Observation - Observación</i>
8029.80.305	12/24V	2 terminais lingueta 6,3mm <i>2 Terminals with 6,3 mm Tab 2 Terminales de Lengüeta de 6,3 mm</i>	Frontal <i>Front - Frontal</i>	Fio 1100mm <i>1100mm Wire - Cables 1100mm</i>



### 8037 | Lanterna Interna Ø 65mm

Ø 65mm Internal Light | Luz Interna Ø 65mm

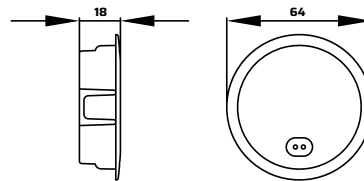

Código <i>Code - Código</i>	Tensão <i>Voltage - Voltaje</i>	Conexão <i>Connection - Conexión</i>	Fixação <i>Fixation - Fijación</i>	Observação <i>Observation - Observación</i>
8037.70.305	12/24V	Terminal Faston Com Isolador 2 Vias <i>Faston Terminal with Isolador, 2-Way Terminal Faston con Aislador, 2 Vias</i>	Embutir <i>Recessed - Empotrado</i>	Fios 140mm   Flange cinza <i>140 mm Wires   Gray Flange Cables de 140 mm   Flange Gris</i>
8037.90.305				Fios 180mm   Flange cinza claro <i>180 mm Wires   Light Gray Flange Cables de 180 mm   Flange Gris Claro</i>



### 8137 | Lanterna Interna Mini Dicroica

Mini Dichroic Interior Light | Linterna Interior Mini Dicroica

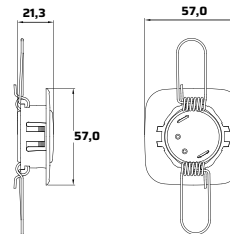

Código <i>Code - Código</i>	Tensão <i>Voltage - Voltaje</i>	Conexão <i>Connection - Conexión</i>	Fixação <i>Fixation - Fijación</i>	Observação <i>Observation - Observación</i>
8137.80.305	12/24V	Faston 2 vias <i>2-way Faston - Faston de 2 vias</i>	Embutir <i>Recessed - Empatrar</i>	-
8137.81.305				
8137.82.305				
8137.83.305				



## 8037 | Lanterna Interna Ø 85mm

Ø 85mm Internal Light | Luz Interna Ø 85mm

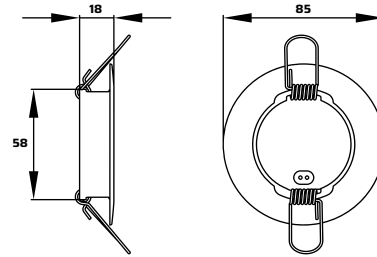

Código <i>Code - Código</i>	Tensão <i>Voltage - Voltaje</i>	Conexão <i>Connection - Conexión</i>	Fixação <i>Fixation - Fijación</i>	Observação <i>Observation - Observación</i>
8037.71.305	12/24V	Terminal Faston Com Isolador 2 Vias <i>Faston Terminal with Insulator, 2-Way Terminal Faston con Aislador, 2 Vias</i>	Embutir <i>Recessed - Empotrado</i>	Fios 140mm   Flange cinza <i>140 mm Wires   Gray Flange Cables de 140 mm   Flange Gris</i>
8037.91.305				Fios 180mm   Flange cinza claro <i>180 mm Wires   Light Gray Flange Cables de 180 mm   Flange Gris Clara</i>



## 8999 | Lanterna Saída de Emergência

Emergency Exit Light | Luz de Salida de Emergencia

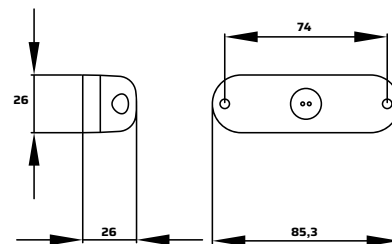

Código <i>Code - Código</i>	Tensão <i>Voltage - Voltaje</i>	Conexão <i>Connection - Conexión</i>	Fixação <i>Fixation - Fijación</i>	Observação <i>Observation - Observación</i>
8999.81.308	12/24V	2 Terminal Faston Com Isolador 1 Vias <i>2 Faston Terminal with Insulator, 1-Way 2 Terminal Faston con Aislador, 1 Vias</i>	Frontal <i>Front - Frontal</i>	Fio 360mm <i>360mm Wire - Cables 360mm</i>

Original  
CAIO



## 8073 | Lanterna Interna Lumi Sobrepor

Lumi Overlapping Internal Light | Luz Interna Lumi Superpuesta

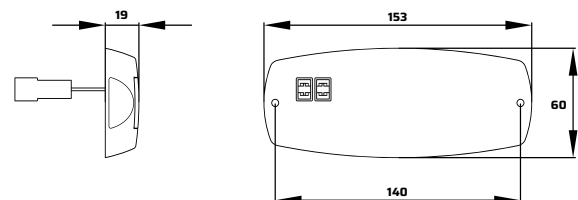

Código <i>Code - Código</i>	Tensão <i>Voltage - Voltaje</i>	Conexão <i>Connection - Conexión</i>	Fixação <i>Fixation - Fijación</i>	Observação <i>Observation - Observación</i>
8073.76.305	12/24V	Terminal Faston Com Isolador 1 Vias <i>Faston Terminal with Insulator, 1-Way Terminal Faston con Aislador, 1 Vias</i>	Frontal <i>Front - Frontal</i>	Fio 180mm   Touch <i>180mm Wire   Touch Cables 180mm   Touch</i>
8073.78.305		Saídas de Fios <i>Wire Outputs - Salidas de Cables</i>		Fio 2000mm <i>2000mm Wire - Cables 2000mm</i>



## 8073 | Lanterna Interna Lumi Embutir

Lumi Recessed Internal Light | Luz Interna Lumi Empotrada

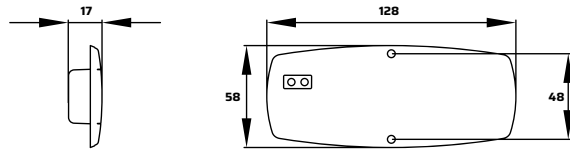

Código <i>Code - Código</i>	Tensão <i>Voltage - Voltaje</i>	Conexão <i>Connection - Conexión</i>	Fixação <i>Fixation - Fijación</i>	Observação <i>Observation - Observación</i>
8073.82.305	12/24V	Saídas de Fios <i>Wire Outputs - Salidas de Cables</i>	Frontal <i>Front - Frontal</i>	Fio 1500mm <i>1500mm Wire - Cables 1500mm</i>



## 8073 | Lanterna Interna Lumi de Canto

Lumi Corner Internal Light | Luz Interna Lumi de Esquina

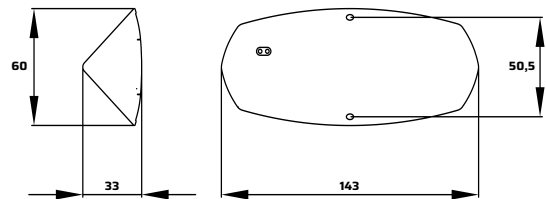

Código <i>Code - Código</i>	Tensão <i>Voltage - Voltaje</i>	Conexão <i>Connection - Conexión</i>	Fixação <i>Fixation - Fijación</i>	Observação <i>Observation - Observación</i>
8073.90.305	12/24V	Terminal Faston Com Isolador 1 Vias <i>Faston Terminal with Isolador, 1-Way</i> <i>Terminal Faston con Aislador, 1 Vias</i>	Frontal <i>Front - Frontal</i>	-
8073.92.305		Saídas de Fios <i>Wire Outputs - Salidas de Cables</i>		



## 8584 | Lanterna Saída de Emergência

Emergency Exit Light | Luz de Salida de Emergencia

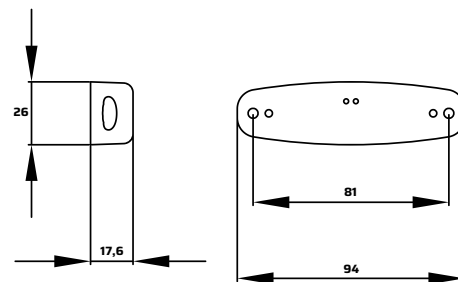

Código <i>Code - Código</i>	Tensão <i>Voltage - Voltaje</i>	Conexão <i>Connection - Conexión</i>	Fixação <i>Fixation - Fijación</i>	Observação <i>Observation - Observación</i>
8584.72.309	12/24V	Terminal Faston Com Isolador 1 Vias <i>Faston Terminal with Isolador, 1-Way</i> <i>Terminal Faston con Aislador, 1 Vias</i>	Frontal <i>Front - Frontal</i>	Fio 180mm <i>180mm Wire - Cables 180mm</i>

Original  
MASCARELLO, IRIZAR, BUSSCAR, MARCOPOLO



# Faróis

---

Faróis Full LED compactos e confiáveis, garantindo máxima visibilidade e segurança.

## **Headlights**

*Compact and reliable full LED headlights, ensuring maximum visibility and safety.*

## **Faros**

*Faros Full LED compactos y confiables, garantizando máxima visibilidad y seguridad.*



## 8268 | Farol Órizzon 5

Órizzon 5 Headlight | Farol Orizzon 5

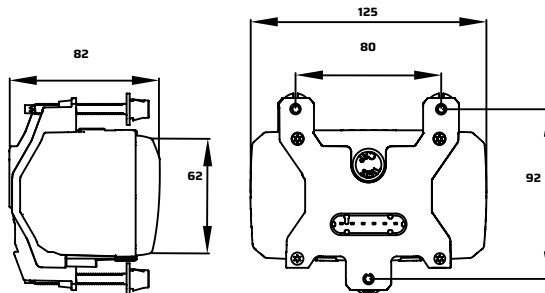

Código <i>Code - Código</i>	Tensão <i>Voltage - Voltaje</i>	Conexão <i>Connection - Conexión</i>	Fixação <i>Fixation - Fijación</i>	Funções <i>Functions - Funciones</i>
8268.80.205	12/24V	Selada 6 Vias <i>6 Pin Sealed - Sellado de 6 Vias</i>	Suporte <i>Mount - Soporte</i>	Baixo   Alto   Posição   DRL   Direcional <i>Low   High   Position   DRL   Directional</i> <i>Baja   Alto   Posición   DRL   Direccional</i>

## 8265 | Farol Órizzon

Órizzon HeadLight | Farol Orizzon

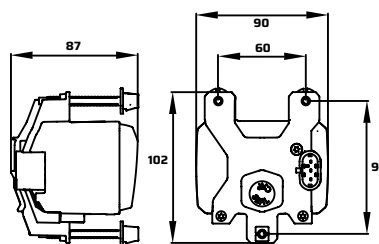

Código <i>Code - Código</i>	Tensão <i>Voltage - Voltaje</i>	Conexão <i>Connection - Conexión</i>	Fixação <i>Fixation - Fijación</i>	Funções <i>Functions - Funciones</i>
8265.80.205	12/24V	Selada 3 Vias <i>3 Pin Sealed - Sellado de 3 Vias</i>	Suporte <i>Mount - Soporte</i>	Baixo   Alto <i>Low   High - Bajo   Alto</i>



## 8266 | Farol de Neblina Nébulas

Nebula Fog Light | Farol Antiniebla Nebula

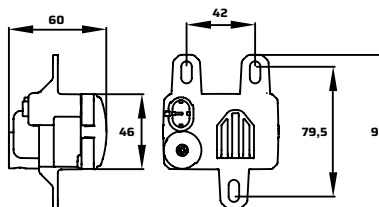

Direito <i>Code - Código</i>	Esquerdo <i>Voltage - Voltaje</i>	Tensão <i>Voltage - Voltaje</i>	Conexão <i>Connection - Conexión</i>	Fixação <i>Fixation - Fijación</i>	Funções <i>Functions - Funciones</i>
8266.81.205	8266.80.205	12/24V	Selada 2 Vias <i>2 Pin Sealed - Sellado de 2 Vias</i>	Suporte <i>Mount - Soporte</i>	Nebolina e cornering <i>Fog and Cornering</i> <i>Niebla y Cornering</i>



## 8269 | Farol de Neblina Kalis

Fog Light Kalis | Faro Antiniebla Kalis

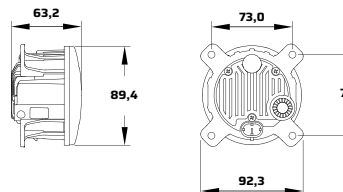

Código <i>Code - Código</i>	Tensão <i>Voltage - Voltaje</i>	Conexão <i>Connection - Conexión</i>	Fixação <i>Fixation - Fijación</i>	Funções <i>Functions - Funciones</i>
8269.80.205	12/24V	Superseal 2 vias	Frontal <i>Front - Frontal</i>	Nebolina e cornering <i>Fog and Cornering - Niebla y Cornering</i>



### 8254 | Farol Full Led Ø110 mm

Ø110 mm Full Led HeadLight | Farol Full Led Ø110 mm

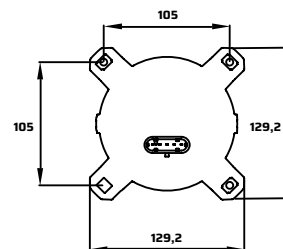
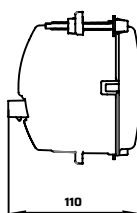

Código <i>Code - Código</i>	Tensão <i>Voltage - Voltaje</i>	Conexão <i>Connection - Conexión</i>	Fixação <i>Fixation - Fijación</i>	Funções <i>Functions - Funciones</i>
8254.85.205	12/24V	Selada 6 Vias <i>6 Pin Sealed - Sellada de 6 Vias</i>	Suporte <i>Mount - Soporte</i>	Baixo   Alto   Posição   DRL   Direcional <i>Low   High   Position   DRL   Directional</i> <i>Bajo   Alto   Posición   DRL   Direccional</i>
8254.81.205		Selada 5 Vias <i>5 Pin Sealed - Sellada de 5 Vias</i>		Baixo   Alto   Posição   DRL <i>Low   High   Position   DRL</i> <i>Bajo   Alto   Posición   DRL</i>



### 8253 | Farol Full Led Ø90 mm

Ø90 mm Full Led HeadLight | Farol Full Led Ø90 mm

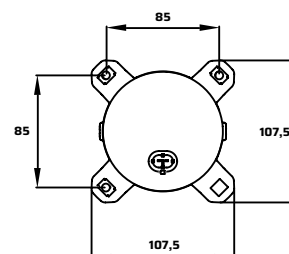
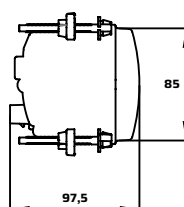

Código <i>Code - Código</i>	Tensão <i>Voltage - Voltaje</i>	Conexão <i>Connection - Conexión</i>	Fixação <i>Fixation - Fijación</i>	Funções <i>Functions - Funciones</i>
8253.84.205	12/24V	Selada 2 Vias <i>2 Pin Sealed - Sellada de 2 Vias</i>	Suporte <i>Mount - Soporte</i>	Baixo <i>Low - Bajo</i>
8253.8K.205				Alto <i>High - Alto</i>
8253.86.205		Selada 3 Vias <i>3 Pin Sealed - Sellada de 3 Vias</i>		Baixo   Alto <i>Low   High - Bajo   Alto</i>



### 8252 | Farol Neblina Ø70 mm

Ø70 mm Fog Light | Faro Anti-Niebla Ø70 mm

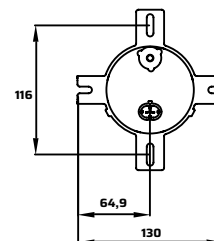
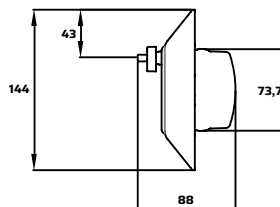

Código <i>Code - Código</i>	Tensão <i>Voltage - Voltaje</i>	Conexão <i>Connection - Conexión</i>	Fixação <i>Fixation - Fijación</i>	Funções <i>Functions - Funciones</i>
8252.81.205	12/24V	Selada 2 Vias <i>2 Pin Sealed - Sellada de 2 Vias</i>	Suporte <i>Mount - Soporte</i>	Neblina <i>Fog - Niebla</i>



# Faróis de trabalho

---

Faróis de LED robustos e confiáveis, trazem alta eficiência para o trabalho no campo. Com opções spot e wide.

## **Work lights**

*Robust and reliable LED headlights, bringing high efficiency for work in the field. With spot and wide options.*

## **Luces de trabajo**

*Faros de LED robustos y confiables, brindan alta eficiencia para el trabajo en el campo. Con opciones spot y wide.*



**8267 | Farol de Trabalho RT3000**

RT3000 Work Light | Farol de Trabajo RT3000

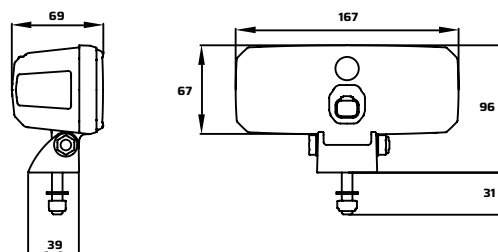

Spot Beam	Wide Beam	Tensão Voltage - Voltaje	Conexão Connection - Conexión	Fixação Fixation - Fijación	Fluxo Luminoso Lumi Flux - Flujo Lumi	Observação Observation - Observación
8267.81.205	8267.80.205	12/24V	Deutsch 2 Vias 2 Pin Deutsch - Deutsch 2 Vias	Suporte Mount - Soporte	3000 lm	-

**8263 | Farol de Trabalho SQ900**

SQ900 Work Light | Farol de Trabajo SQ900

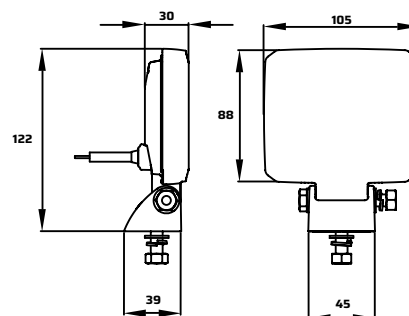

Código Code - Código	Tensão Voltage - Voltaje	Conexão Connection - Conexión	Fixação Fixation - Fijación	Fluxo Luminoso Lumi Flux - Flujo Lumi	Observação Observation - Observación
8263.80.305	12/24V	Saída de fios Wire output - Salida de cable	Suporte Mount - Soporte	900 lm	-

**8264 | Farol de Trabalho RD700**

RD700 Work Light | Faro de Trabajo RD 700

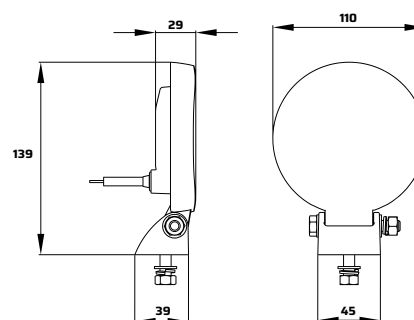

Código Code - Código	Tensão Voltage - Voltaje	Conexão Connection - Conexión	Fixação Fixation - Fijación	Fluxo Luminoso Lumi Flux - Flujo Lumi	Observação Observation - Observación
8264.80.205	12/24V	Saída de fios Wire output - Salida de cable	Suporte Mount - Soporte	700 lm	-



## 8256 | Farol de Trabalho Quadrado

Square Work Light | Faro de Trabajo Cuadrado

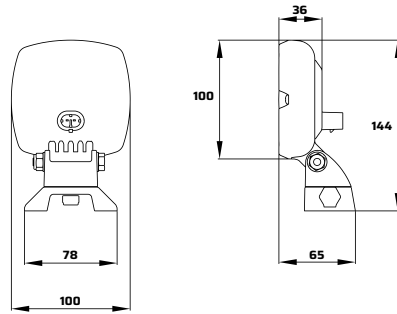

Spot Beam	Wide Beam	Tensão Voltage - Voltaje	Conexão Connection - Conexión	Fixação Fixation - Fijación	Fluxo Luminoso Lumi Flux - Flujo Lumi	Observação Observation - Observación
8256.83.305	8256.84.305	12/24V	Selado 2 Vias 2 Pin Sealed - Sellado de 2 Vias	Suporte Mount - Soporte	420lm	Com base de giro With rotating base Con base de giro
-	8256.86.305					Sem base de giro Without rotating base Sin base de giro



## 8257 | Farol de Trabalho Elíptico

Elliptical Work Light | Faro de Trabajo Elíptico

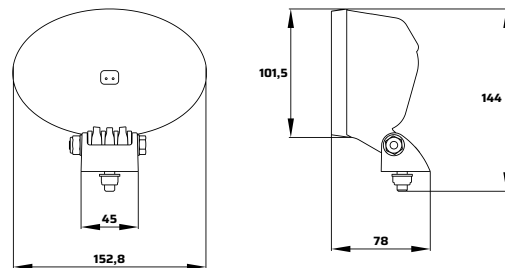

Spot Beam	Wide Beam	Tensão Voltage - Voltaje	Conexão Connection - Conexión	Fixação Fixation - Fijación	Fluxo Luminoso Lumi Flux - Flujo Lumi	Observação Observation - Observación
8257.60.205	8257.62.205	12V	Deutsch 2 Vias 2 Pin Deutsch - Deutsch 2 Vias	Suporte Mount - Soporte	1600 lm	6 LED
-	8257.40.205	48V			2300 lm	8 LED



## 8258 | Farol de Trabalho Redondo

Round Work Light | Faro de Trabajo Redondo

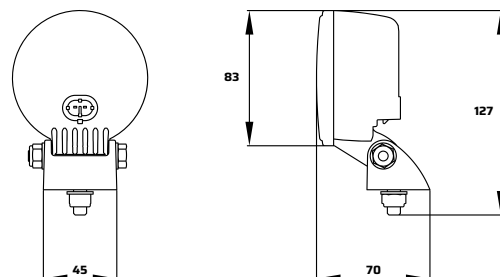

Wide Beam	Tensão Voltage - Voltaje	Conexão Connection - Conexión	Fixação Fixation - Fijación	Fluxo Luminoso Lumi Flux - Flujo Lumi	Observação Observation - Observación
8258.62.205	12V	Selado 2 Vias 2 Pin Sealed - Sellado de 2 Vias	Suporte Mount - Soporte	1000lm	6 LED
8258.62.205	12/24V			2700lm	3 LED



## 8262 | Farol Blue Prime

Blue Prime HeadLight | Farol Blue Prime

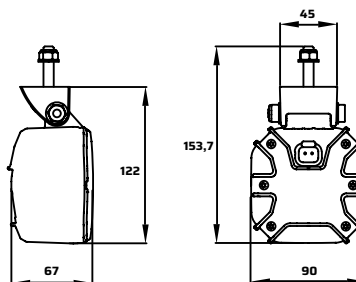

Código <i>Code - Código</i>	Tensão <i>Voltage - Voltaje</i>	Conexão <i>Connection - Conexión</i>	Fixação <i>Fixation - Fijación</i>	Observação <i>Observation - Observación</i>
8262.41.205	12/48V	Deutsch 2 Vias 2 Pin Deutsch - Deutsch 2 Vias	Superior Superior - Superior	-



## 8262 | Farol Red Line

Red Line HeadLight | Farol Red Line

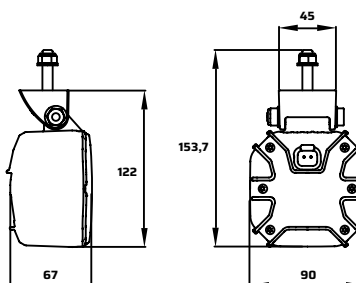

Código <i>Code - Código</i>	Tensão <i>Voltage - Voltaje</i>	Conexão <i>Connection - Conexión</i>	Fixação <i>Fixation - Fijación</i>	Observação <i>Observation - Observación</i>
8262.40.205	12/48V	Deutsch 2 Vias 2 Pin Deutsch - Deutsch 2 Vias	Superior Superior - Superior	-



## 8255 | Farol de Trabalho Elíptico

Elliptical Work Light | Luz de Trabajo Elíptica

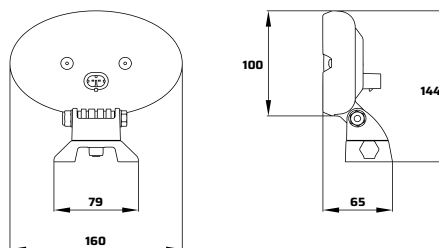

Spot Beam	Wide Beam	Tensão <i>Voltage - Voltaje</i>	Conexão <i>Connection - Conexión</i>	Fixação <i>Fixation - Fijación</i>	Fluxo Luminoso <i>Lumi Flux - Flujo Lumi</i>	Observação <i>Observation - Observación</i>
-	8255.68.305	12/24V	Selada 2 Vias 2 Pin Sealed - Sellado de 2 Vias	-	600 lm	Sem Suporte <i>Without support Sin soporte</i>
8255.80.305	-			-		Com parafuso da base maior <i>With a larger base screw Con un tornillo de base más grande</i>
8255.82.305	8255.83.305			Suporte <i>Mount - Soporte</i>		Com base de giro <i>With rotating base Con base de giro</i>
-	-			-		Blue Spot



# Peças técnicas

---

Produtos injetados de alta qualidade, resistentes e duráveis, sendo soluções práticas para diversas aplicações.

## **Technical parts**

*High quality injected products, resistant and durable, being practical solutions for various applications.*

## **Piezas Técnicas**

*Productos inyectados de alta calidad, resistentes y duraderos, siendo soluciones prácticas para diversas aplicaciones.*



## 8410 | Caixa de Ferramentas

Storage Tool Box | Caja de Herramientas

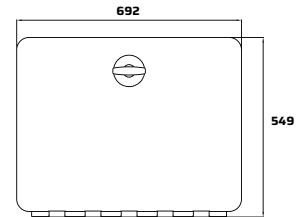
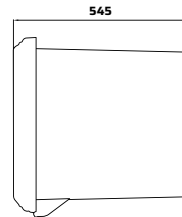

Código <i>Code - Código</i>	Observação <i>Observation - Observación</i>
8410.00.400	Caixa 690x530x550mm <i>Box - Caja</i>

Original

LIBRELATO, ENOVA, RODO VALE, METALESP, PALMEIRA ESTRADA, OLIVO, GUERRA, FURGÕES JOINVILLE, GOTTI



## 4499 | Carenagem Traseira

Rear Fairing - Carenado Trasero

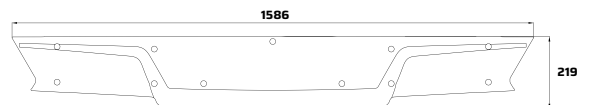

Código <i>Code - Código</i>	Observação <i>Observation - Observación</i>
4499.01.409	Duct Wide
4499.04.409	Wings, Gemini, Volkan

Original

ESTRADA

## 4053 | Carenagem Envolvente e Semi Envolvente

Enclosing and Semi-Enclosing Fairing - Carenado Envolvente y Semi Envolvente

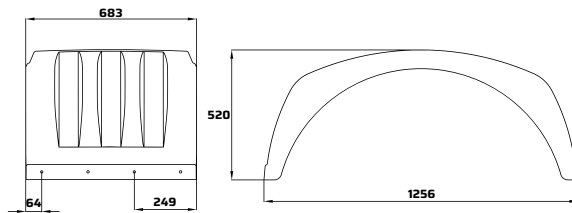

Código <i>Code - Código</i>	Observação <i>Observation - Observación</i>
4053.03.409	Com Logo Envolvente <i>With Enclosing Logo - Con Logo Envolvente</i>
4053.13.409	Com Logo Semi-envolvente A <i>With Semi-Enclosing Logo A - Con Logo Semi-Envolvente A</i>
4053.23.409	Com Logo Semi-envolvente B <i>With Semi-Enclosing Logo B - Con Logo Semi-Envolvente B</i>

Original  
NOMA

## 4968 | Carenagem Lateral

Side Fairing - Carenado Lateral

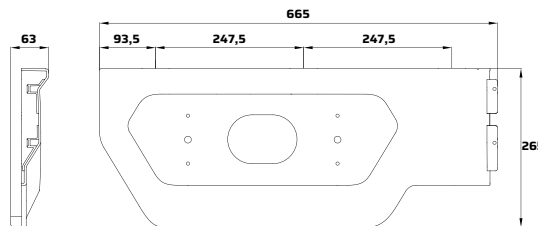

Direito <i>Right - Derecho</i>	Esquerda <i>Left - Izquierda</i>	Observação <i>Observation - Observación</i>
4968.00.409	4968.01.409	665mm Lado Direito <i>Right Side 665mm - 665mm Lado Derecho</i>
4968.10.409	4968.11.409	665mm Lado Esquerdo <i>Left Side 665mm - 665mm Lado Izquierdo</i>

Original  
GUERRA

## 4346 | Acabamento de Poltrona Lateral

Seat Backrest Trim | Acabado de Respaldo de Butaca

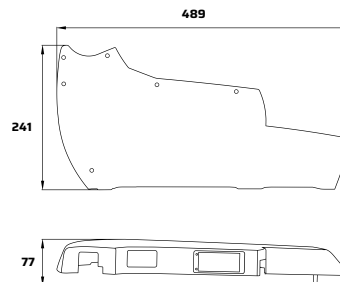

Direito <i>Right - Derecho</i>	Esquerda <i>Left - Izquierda</i>
4346.LD.442	4346.LE.442

Original  
BUSSCAR



### 4064 | Suporte Lanterna 8064

Light Support 8064 | Suporte para Luz 8064

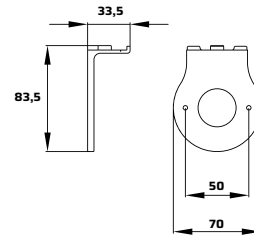

Código <i>Code - Código</i>	Observação <i>Observation - Observación</i>
4064.90.409	Lanterna 8084 8084 Light - Luz 8084



### 4099 | Suporte Lanterna 8099

Light Support 8099 | Suporte para Luz 8099

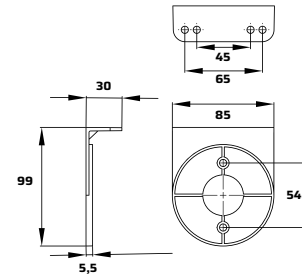

Código <i>Code - Código</i>	Observação <i>Observation - Observación</i>
4099.92.409	Lanterna 8099 8099 Light - Luz 8099



### 4493 | Suporte de Lanterna

Closed Key Support | Soporte de Tecla Cerrada

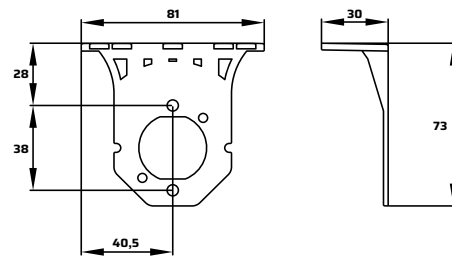

Código <i>Code - Código</i>	Observação <i>Observation - Observación</i>
4493.01.409	Lanterna 8540 8540 Light - Luz 8540
4493.04.409	Lanterna 8547 8547 Light - Luz 8547



### 4307 | Suporte Placa Risco | Segurança

Risk Plate Support | Safety | Soporte de Placa de Riesgo | Seguridad

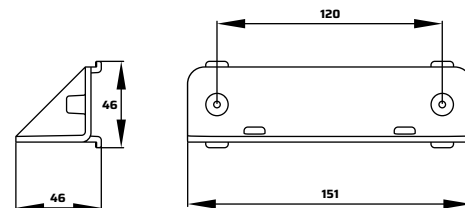

Código <i>Code - Código</i>	Observação <i>Observation - Observación</i>
4307.00.409	Com Parafuso With Screws - Con Tornillos
8300.70.000	Sem Parafuso Without Screws - Sin Tornillos

### 4961 | Suporte Lanterna 8961

Light Support 8961 | Soporte de Luz 8961

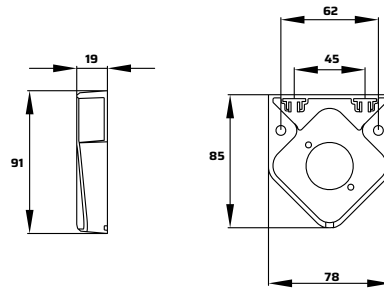
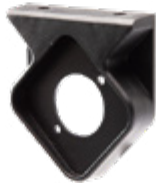

Código
Code - Código
4307.00.409

### 8075 | Suporte de Placa

Plate Bracket | Soporte de Placa

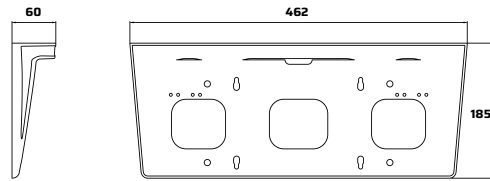

Código	Observação
Code - Código	Observation - Observación
4075.10.409	Sem Lanterna Withou Lantern - Sin Luz
8075.10.000	Com Lanterna With Lantern - Con Luz



### 8075 | Suporte de Placa

Plate Bracket | Soporte de Placa

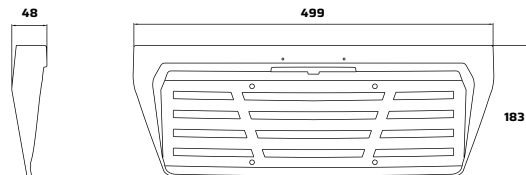

Código	Observação
Code - Código	Observation - Observación
4075.20.409	Sem Lanterna Withou Lantern - Sin Luz
8075.20.000	Com Lanterna With Lantern - Con Luz

Original  
ESTRADA



### 8422 | Conjunto Puxador de Janela

Window Handle Assembly | Conjunto de Manija de Ventana

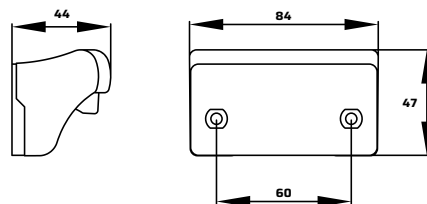

Código
Code - Código
8422.00.000



### 8300 | Suporte Rótulo de Risco

Risk Label Support | Soporte Rótulo de Risco

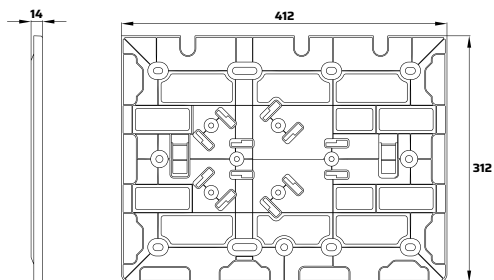
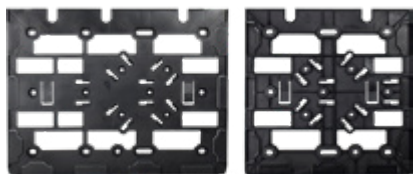

Código <i>Code - Código</i>	Observação <i>Observation - Observación</i>
8300.04.000	312x312mm
8300.05.000	312x412mm

Original

RANDO, NOMA, RODOTECNICA, LIBRELATO, GUERRA, IBIPORÃ

### 4403 | Suporte Tecla

Key Support | Soporte de Tecla

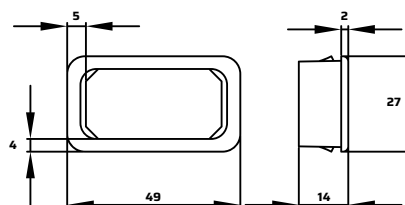

Código <i>Code - Código</i>
4403.90.109



### 4404 | Suporte Tecla Fechado

Closed Key Support | Soporte de Tecla Cerrado

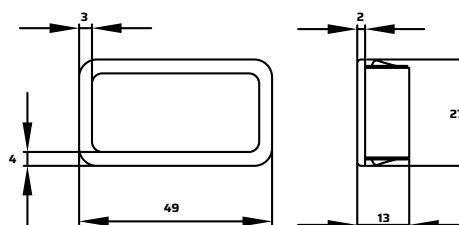

Código <i>Code - Código</i>
4404.90.109



### 4036 | Grade Dianteira

Grade Diant | Supporte Frontal

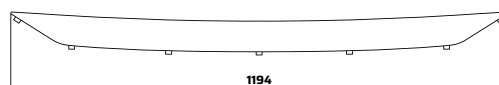

Código <i>Code - Código</i>
4036.00.409

Original

COMIL



### 8462 | Conjunto Corta Pingo com Tampa

Drip Stop Assembly with Cover | Conjunto Corta Pingo con Tapa

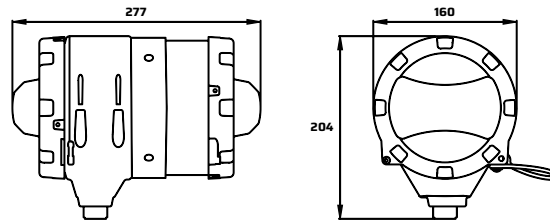

Código
<i>Code - Código</i>
8462.00.409



### 8610 | Conjunto Saída de Ar

Air Outlet Assembly | Conjunto de Salida de Aire

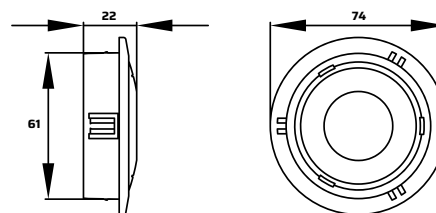

Código	Fixação	Observação
<i>Code - Código</i>	<i>Fixation - Fijación</i>	<i>Observation - Observación</i>
8610.00.464	Embutir <i>Recessed - Empotrado</i>	Cinza <i>Gray - Gris</i>



### 8959 | Conjunto Máscara

Mask Set | Conjunto de Mascara

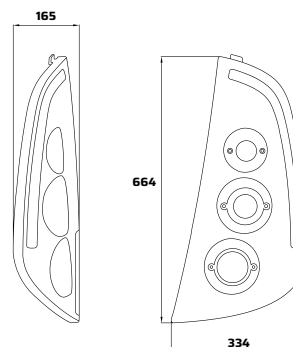

Direito	Esquerda
<i>Right - Derecho</i>	<i>Left - Izquierda</i>
8959.LD.000	8959.LE.000



### 4303 | Passador

Passer | Pasador

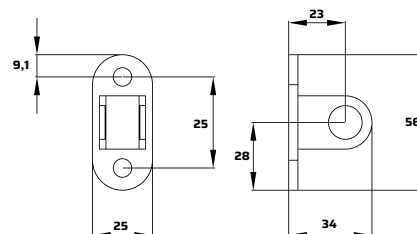

Código
<i>Code - Código</i>
4303.90.607



## 8714 | Porta Focos

Bulb Holder | Porta Focos

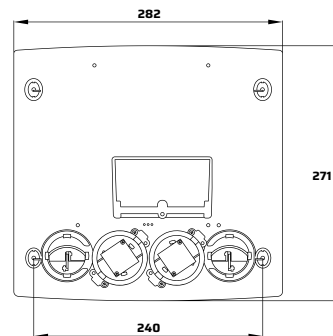
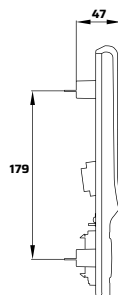

Código <i>Code - Código</i>	Fixação <i>Fixation - Fijación</i>	Observação <i>Observation - Observación</i>
8714.02.000	Frontal <i>Front - Frontal</i>	-
8714.02.001		Sem Som e Rodomoça <i>Without Sound and Steward sin Sonido y Azafata</i>



## 8967 | Máscara Dianteira

Front Mask | Máscara Delantera

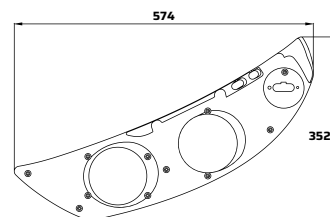
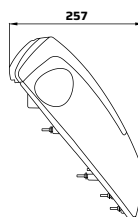

Direito <i>Right - Derecha</i>	Esquerda <i>Left - Izquierda</i>
8967.LD.001	8967.LE.001
8967.LD.003	8967.LE.003



## 4302 | Passador

Passer | Pasador

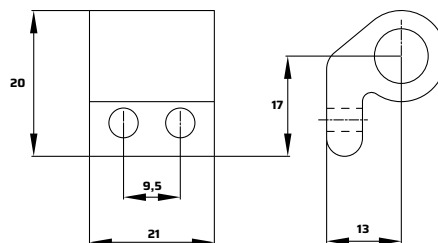

Código <i>Code - Código</i>	Observação <i>Observation - Observación</i>
4302.90.409	Preto <i>Black - Negro</i>
4302.90.468	Cinza <i>Gray - Gris</i>



### 4324 | Espaçador Tira Fino

Thin Strip Spacer - Espaciador de Banda Fina

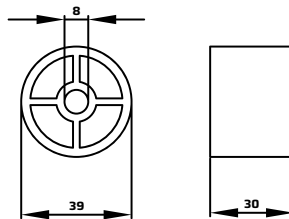

Código
Code - Código
4324.00.409

Original  
NOMA

### 4304 | Passador

Passer | Pasador

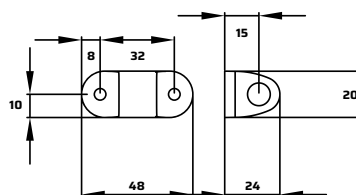

Código	Observação
Code - Código	Observation - Observación
4304.90.409	Preto Black - Negro
4304.90.465	Cinza Gray - Gris
4304.90.466	Cinza Claro Light Gray - Gris Claro



### 4309 | Passador

Passer | Pasador

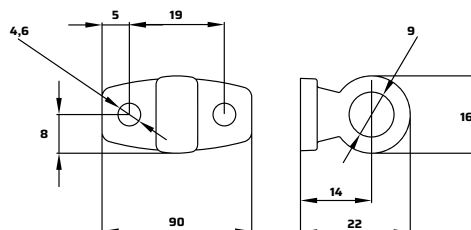

Código	Observação
Code - Código	Observation - Observación
4309.90.607	Natural Natural - Natural
4309.90.609	Preto Black - Negro



### 4405 | Batente

Bumper | Tape

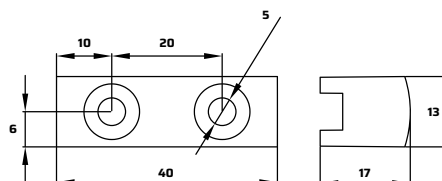

Código
Code - Código
4405.90.409

## 4401 | Porta Copos

Cup Holder | Portavasos

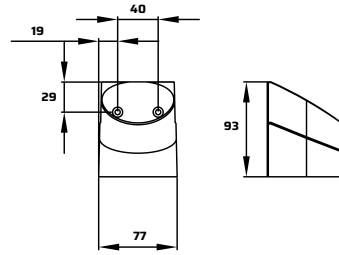

Código <i>Code - Código</i>	Observação <i>Observation - Observación</i>
4401.90.409	Preto <i>Black - Negro</i>
4401.90.465	Cinza <i>Gray - Gris</i>



## 4514 | Máscara Traseira Rubi

Ruby Rear Mask | Máscara Trasera Rubi

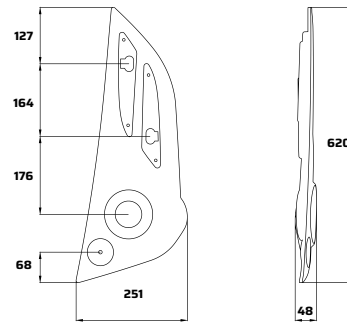

Direito <i>Right - Derecho</i>	Esquerda <i>Left - Izquierdo</i>
4514.01.302	4514.11.302



## 4349 | Manípulo de Poltrona Corredor

Aisle Seat Adjustment Handle | Manija de Ajuste del Asiento del Pasillo

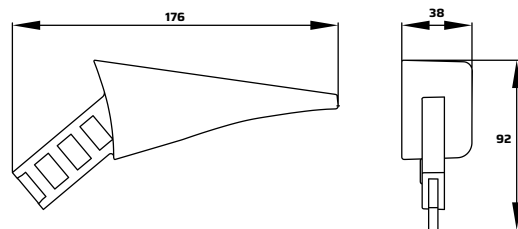

Direito <i>Right - Derecho</i>	Esquerdo <i>Left - Izquierdo</i>
4349.LD.643	4349.LD.643



### 4344 | Tampa Plástica Comando de Som

Plastic Sound Control Cover | Tapa de Plástico para Control de Sonido

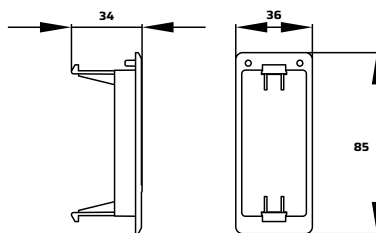

Código

Code - Código

4344.00.443



### 4350 | Manípulo de Poltrona Janela

Window Seat Adjustment Handle | Manija de Ajuste del Asiento de la Ventana

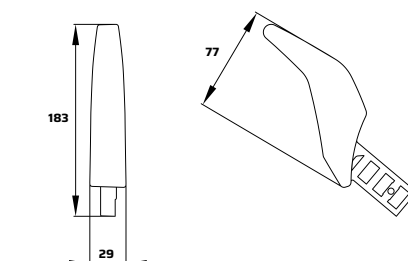

Código

Code - Código

4350.00.643



### 4669 | Base de Assento

Seat Base | Base de Asiento

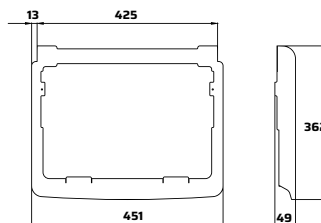

Código

Code - Código

4669.00.107



### 4665 | Garra Plástica

Plastic CLight | Garra Plástica

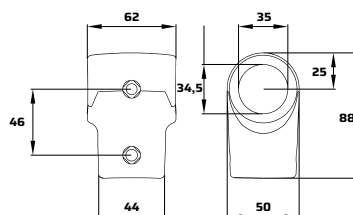

Código

Code - Código

4665.34.406

### 4640 | Garra Plástica

Plastic CLight | Garra Plástica

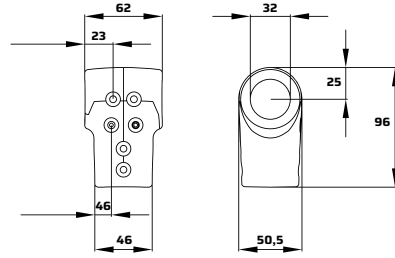

Código	
Code - Código	
4640.32.466	



### 4657 | Garra Plástica

Plastic CLight | Garra Plástica

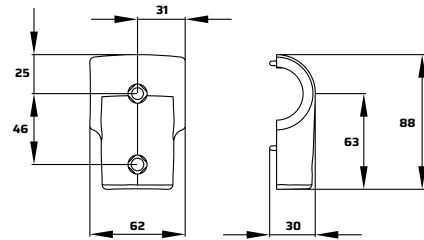

Código	
Code - Código	
4657.34.476	



### 4663 | Garra Plástica

Plastic CLight | Garra Plástica

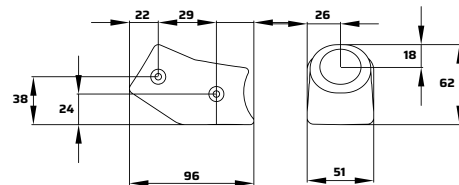

Código	
Code - Código	
4663.25.476	



### 4515 | Máscara Diateira

Front Mask | Máscara Delantera

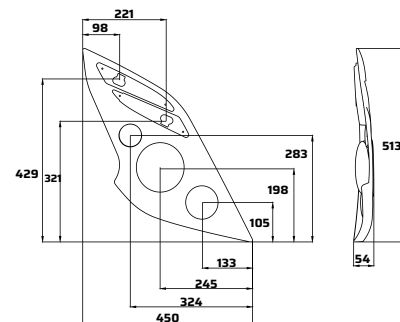

Direito	Esquerda
Right - Derecho	Left - Izquierdo
4515.LD.402	4515.LE.402

## 4959 | Máscara Traseira Rubi | Cinza

Ruby/Gray Rear Mask | Máscara Trasera Rubí | Cinza

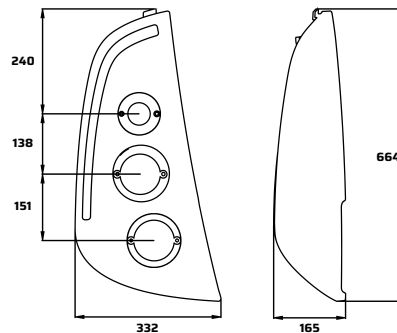

Direito <i>Right - Derecho</i>	Esquerda <i>Left - Izquierda</i>	Observação <i>Observation - Observación</i>
4959.LD.000	4959.LE.000	Rubi e Cinza <i>Ruby and gray - Rubí y gris</i>
4959.LD.001	4959.LE.001	Cinza <i>Gray - Gris</i>



## 4967 | Máscara Dianteira

Front Mask | Máscara Delantera

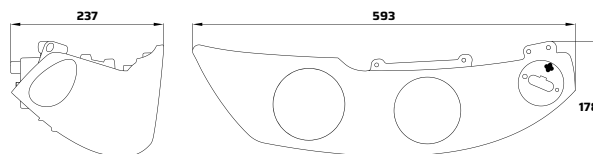

Direito <i>Right - Derecho</i>	Esquerda <i>Left - Izquierdo</i>
4967.02.107	4967.12.107

## 8712 | Porta Focos

Bulb Holder | Porta Focos

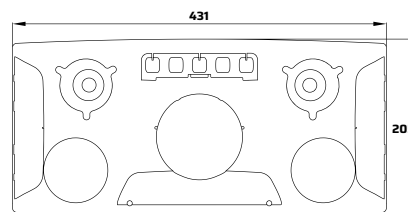
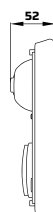

Código <i>Code - Código</i>
8712.00.002



### 8360 | Apoio de Braço

Armrest | Apoyabrazos

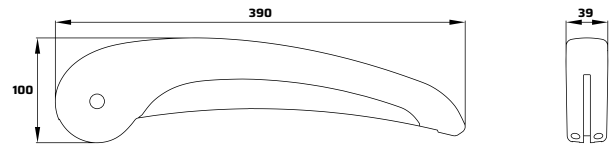

<b>Código</b> <i>Code - Código</i>
8360.00.001



### 8361 | Apoio de Braço

Armrest | Apoyabrazos

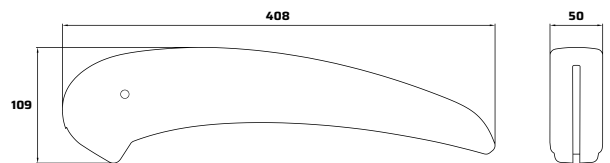

<b>Direito</b> <i>Right - Derecho</i>	<b>Esquerda</b> <i>Left - Izquierdo</i>
8361.LD.001	8361.LE.001



### 8381 | Apoio de Braço

Armrest | Apoyabrazos

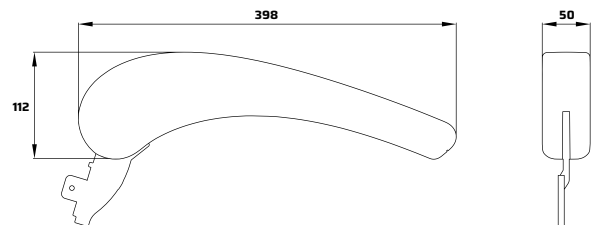

<b>Direito</b> <i>Right - Derecho</i>	<b>Esquerda</b> <i>Left - Izquierdo</i>
8381.LD.001	8381.LE.001



### 8046 | Apoio de Braço

Armrest | Apoyabrazos

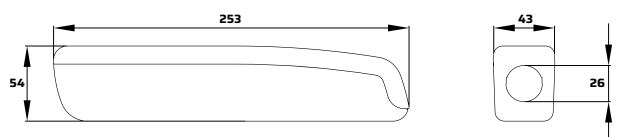

<b>Código</b> <i>Code - Código</i>
8046.00.000



# Acessórios elétricos e eletrônicos

Acessórios, conectores, chicotes e cabos de alta qualidade e confiabilidade.

## **Electrical/electronic accessories**

*High quality and reliable accessories, connectors, harnesses and cables.*

## **Accesorios eléctricos/electrónicos**

*Accesorios, conectores, arneses y cables de alta calidad y confiabilidad.*



**8210 | Dispositivo Controle de Led (DCL)**

LED Control Device (LCD) | Dispositivo de Control de LED (DCL)



Código <i>Code - Código</i>	Tensão <i>Voltage - Voltaje</i>	Conexão <i>Connection - Conexión</i>	Fixação <i>Fixation - Fijación</i>	Observação <i>Observation - Observación</i>
8210.24.000	-	Saída de Fios <i>Wire Outlet - Salida de Cables</i> 7 Vias	Frontal <i>Front - Frontal</i>	-
8210.24.001		Roscado Femea 7 Vias   Roscado Macho <i>Female Threaded 7-Way   Male Threaded 7-Way</i> Roscado Hembra 7 Vias   Roscado Macho 7 Vias		

**8207 | Caixa de Derivação DCL + Flasher**

Flasher + DCL Junction Box | Intermitente + Caja de Conexiones DCL



Código <i>Code - Código</i>	Tensão <i>Voltage - Voltaje</i>	Conexão <i>Connection - Conexión</i>	Fixação <i>Fixation - Fijación</i>	Observação <i>Observation - Observación</i>
8207.24.000	24V	6Sel. 2Vias   1Sel. 3Vias   2 Sel. 5Vias   Rosc. 7Vias <i>6 Seal 2-Way   1 Seal 3-Way   2 Seal 5-Way   Thr 7-Way</i> 6Sell. 2Vias   1 Sell. 3Vias   2 Sell. 5Vias   Ros 7Vias	Frontal <i>Front - Frontal</i>	Conjunto Traseiro <i>Rear Assembly - Conjunto Trasero</i>
8207.24.001		6Sel. 2Vias   1Sel. 3Vias   2 Sel. 5Vias   Rosc. 7Vias <i>6 Seal 2-Way   1 Seal 3-Way   2 Seal 5-Way   Thr 7-Way</i> 6Sell. 2Vias   1 Sell. 3Vias   2 Sell. 5Vias   Ros 7Vias		Conjunto Intermediário <i>Intermediate Assembly - Conjunto Intermedio</i>

Original  
COMIL**8206 | Sirene de Ré**

Reverse Siren | Sirena de Reversa



Código <i>Code - Código</i>	Tensão <i>Voltage - Voltaje</i>	Conexão <i>Connection - Conexión</i>	Fixação <i>Fixation - Fijación</i>	Observação <i>Observation - Observación</i>
8206.60.609	12V	Selado 2 Vias <i>2 Pin Sealed - Sellado de 2 Vias</i>	Suporte <i>Mount - Soporte</i>	-
8206.80.609	12/24V			Bitonal <i>Bitone - Bitonal</i>



### 3203 | **Conjunto DCL Plus + Flasher**

DCL Plus Assembly + Flasher | Conjunto DCL Plus + Flasher



Código <i>Code - Código</i>	Tensão <i>Voltage - Voltaje</i>	Conexão <i>Connection - Conexión</i>	Observação <i>Observation - Observación</i>
3203.80.000	12/24V	Saída de Fios <i>Wire Outlet - Salida de Cables</i>	-



### 3800 | **Chicote Principal ABS + DCL**

Main ABS Harness + DCL | Arnés Principal ABS + DCL



Código <i>Code - Código</i>
3800.25.003



### 3800 | **Chicote Principal Sirene de Ré | Direcional**

Main Wiring Harness for Reverse Siren | Turn Signal | Cableado Principal para Sirena de Marcha Atrás | Direcional



Código <i>Code - Código</i>
3800.30.000



### 4321 | **Conector Snap In**

Snap-In Connector | Conector Snap In



Código <i>Code - Código</i>
4321.90.401



### 4326 | **Vedação CR 2 vias**

CR 2-Way Sealing | Sellado CR de 2 Vías



Código <small>Code - Código</small>	Observação <small>Observation - Observación</small>
4326.30.709	Vedação <small>Sealing - Sellado</small>



### 3800 | **Chicote Principal CRM 7 vias**

Main CRM 7-Way Harness | Arnés Principal CRM de 7 Vías



Código <small>Code - Código</small>	Observação <small>Observation - Observación</small>
3800.00.002	11.500mm
3800.17.006	17.500mm



### 3800 | **Chicote principal CRM 7 vias | ABS**

ABS Main CRM 7-Way Harness | Arnés Principal CRM de 7 Vías ABS



Código <small>Code - Código</small>
3800.28.000



### 3800 | **Chicote Principal Sirene de Ré | Direcional**

Main Harness Reverse Siren | Turn Signal | Arnés Principal Sirena de Reversa | Direccional



Código <small>Code - Código</small>
3800.30.000



### 3099 | Chicote Conector Selado

Sealed Connector Harness | Arnés de Conector Sellado

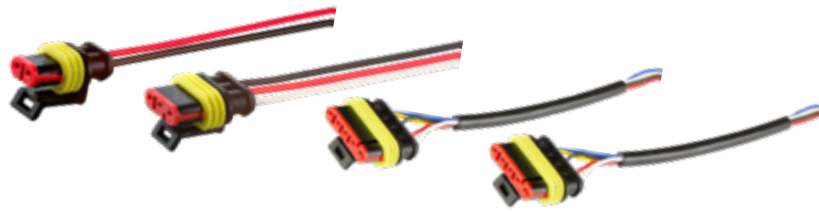

Código <i>Code - Código</i>	Conector <i>Connector - Conector</i>	Observação <i>Observation - Observación</i>
3099.00.011	2 vias 2 way - 2 vias	140mm
3099.10.001	3 vias 3 way - 3 vias	140mm
3056.00.003	4 vias 4 way - 4 vias	180mm
3840.05.003	5 vias 5 way - 5 vias	200mm



### 3099 | Conector | Vedação CR 2 vias

Connector | CR 2-Way Sealing | Conector | Sellado CR de 2 Vías



Código <i>Code - Código</i>	Observação <i>Observation - Observación</i>
3099.00.010	Com 2 Terminais Faston Com Isolador <i>With 2 Faston Terminals with Insulator</i> <i>Con 2 Terminales Faston con Aislador</i>



### 3810 | Chicote Traseiro Conector Tyco

Rear Harness Tyco Connector | Arnés Trasera Conector Tyco



Código <i>Code - Código</i>	Observação <i>Observation - Observación</i>
3810.02.000	1700mm / 1100mm
3810.02.001	2X 1700mm
3810.11.000	-



### 3800 | Chicote Principal Flasher + ABS

Main Harness Flasher + ABS | Arnés Principal Flasher + ABS



Código <i>Code - Código</i>
3800.58.000

### 3830 | Chicote Auxiliar Ponte CRF 2 vias

Auxiliary Harness CRF 2-Way Bridge | Arnés Auxiliar Puente CRF de 2 Vías



Código <i>Code - Código</i>
3830.03.004



### 3840 | Chicote Adaptação

Adaptation Harness | Arnés de Adaptación



Direito <i>Right - Derecho</i>	Esquerdo <i>Left - Izquierdo</i>
3840.05.009	3840.05.010



### 3840 | Chicote Roscado 7 vias

Threaded 7-Way Harness | Arnés Roscado de 7 Vías



Código <i>Code - Código</i>	Observação <i>Observation - Observación</i>
3840.31.000	Lanterna 8593 <i>8593 Light - Luz 8593</i>
3840.31.001	
3840.31.002	Lanterna 8520 <i>8520 Light - Luz 8520</i>



### 3840 | Chicote Elétrico CR 7 vias

CR 7-Way Wiring Harness | Arnés Eléctrico CR de 7 Vías



Direito <i>Right - Derecho</i>	Esquerdo <i>Left - Izquierdo</i>
3840.05.001	3840.05.002



### 3202 | Cabo PP Chato 2 X 0,75

Flat PP Cable 2 x 0,75 | Cable PP Plano 2 X 0,75



Código <i>Code - Código</i>	Observação <i>Observation - Observación</i>
3302.00.305	5000mm

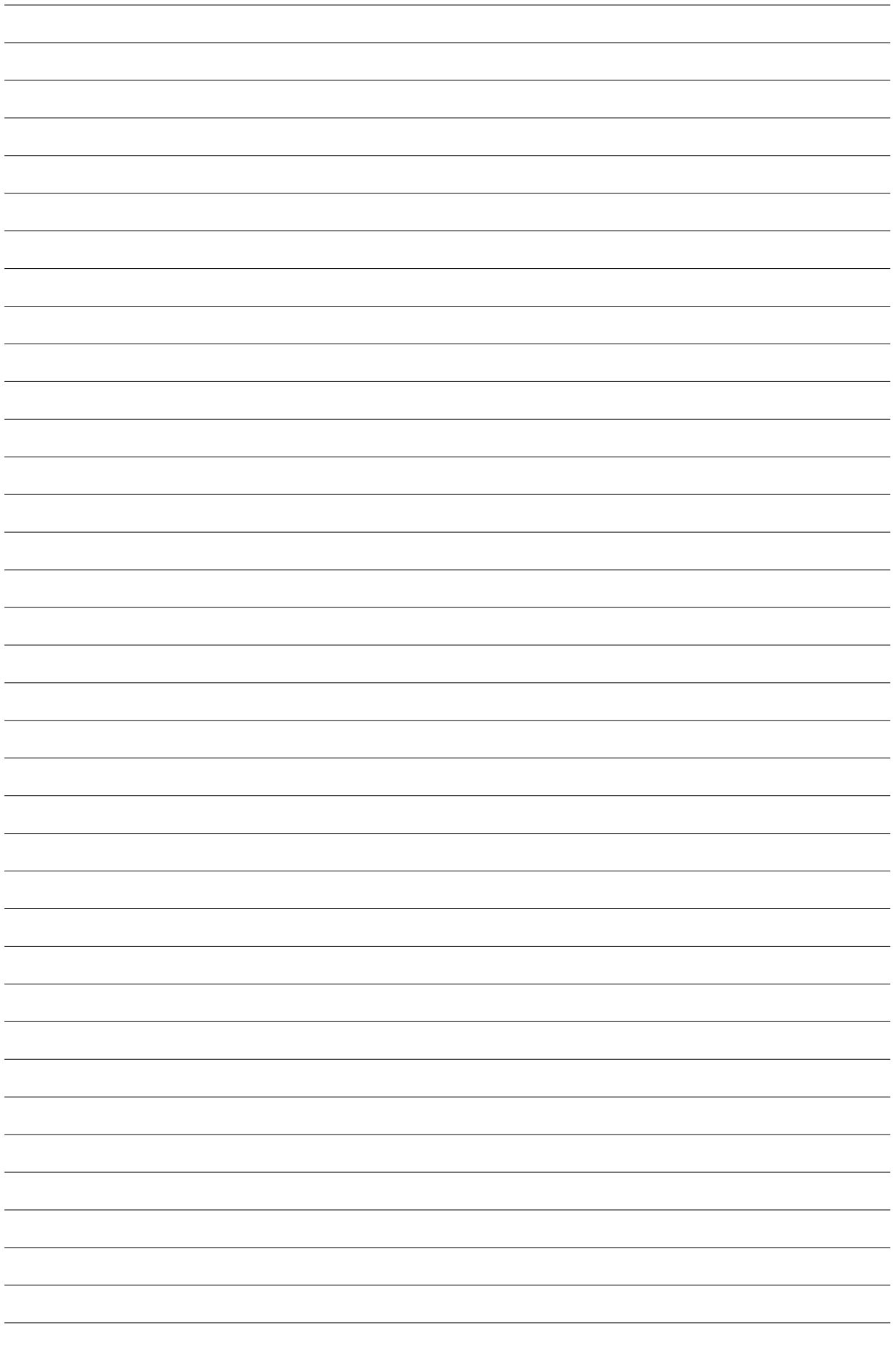

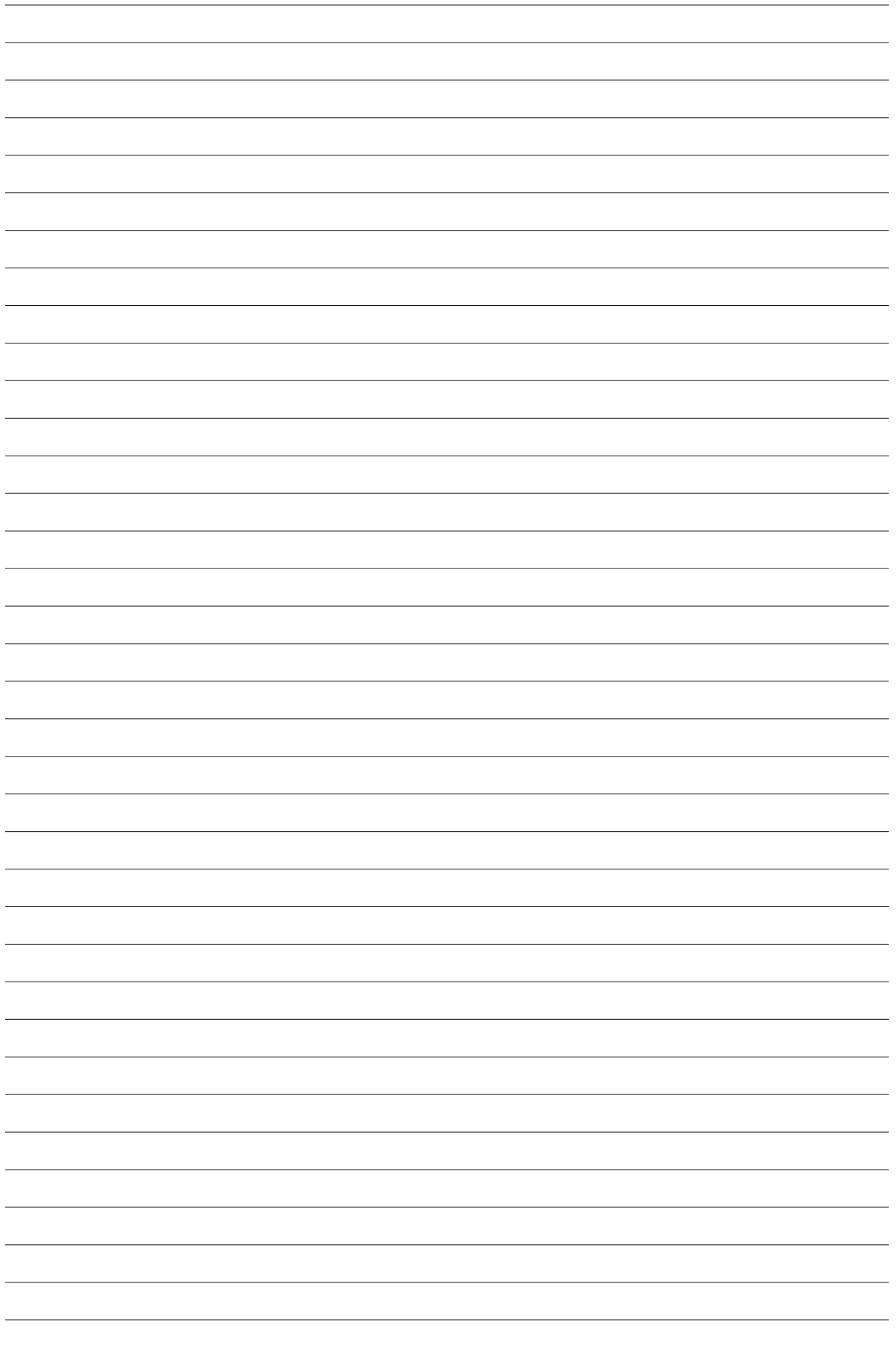

**CELEBRAR 50 ANOS**  
É VALORIZAR CADA  
PARCERIA QUE ILUMINA  
A NOSSA TRAJETÓRIA.



**BRASLUX**   
Revelando horizontes.

**50**   
ANOS

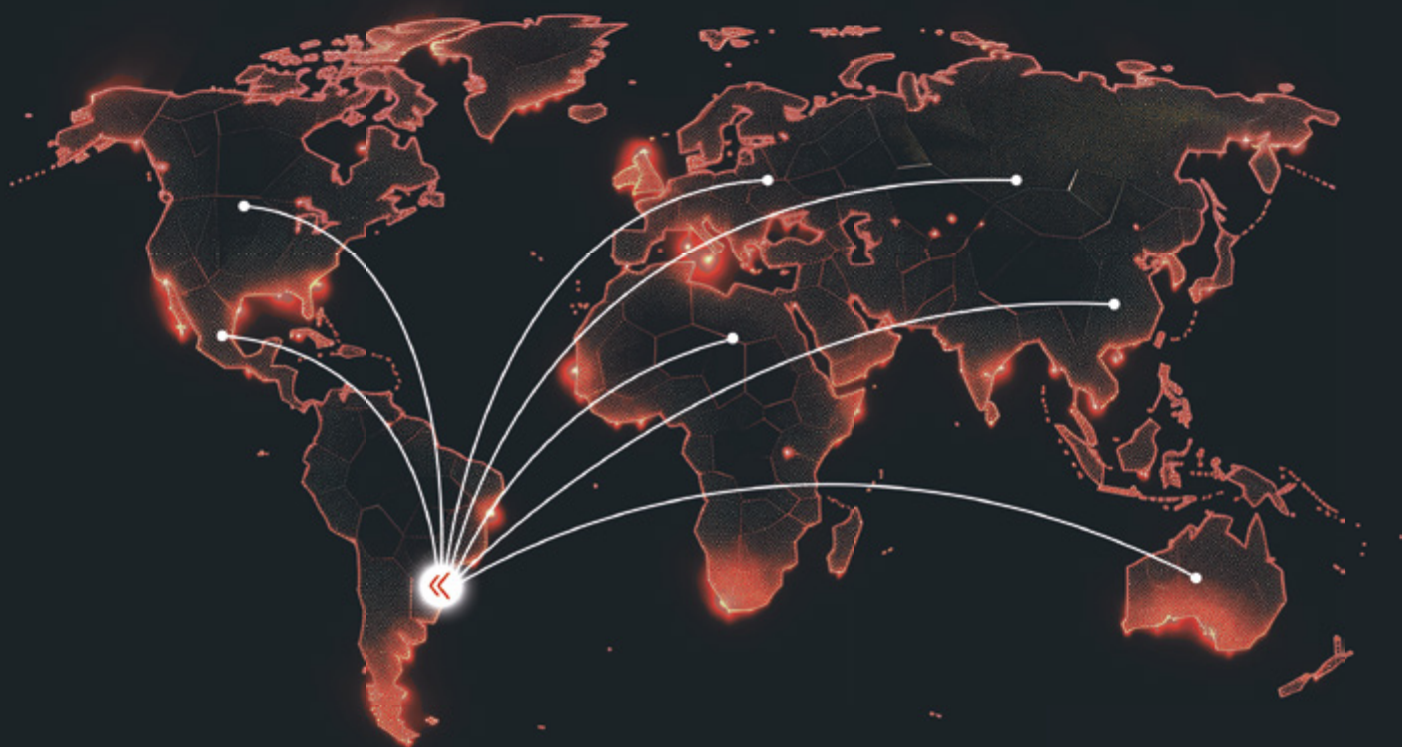

A Braslux vai além da liderança no mercado brasileiro de sistemas de iluminação e peças técnicas injetadas. É uma marca de alcance global, destacada pelo compromisso contínuo com o desenvolvimento de soluções inovadoras.

*Braslux is more than just a leader in the Brazilian market for lighting systems and injection-molded technical parts. It is a global brand, demonstrated by its ongoing commitment to developing innovative solutions.*

*Braslux es más que un líder en el mercado brasileño de sistemas de iluminación y piezas técnicas inyectadas. Es una marca de nivel global, evidenciada por su compromiso continuo con el desarrollo de soluciones innovadoras.*



**Acesse nosso catálogo digital  
Ideia2001.**  
Access our digital catalog  
Ideia2001.  
Accede a nuestro catálogo digital  
Ideia2001.



**Compre online na Loja Oficial  
do Mercado Livre.**  
Buy online at the Official Mercado  
Livre Store  
Compra en línea en la Tienda Oficial de  
Mercado Libre.



**Visite o nosso site e saiba mais  
sobre os produtos.**  
Visit our website and learn more about our  
products.  
Visita nuestro sitio web y conoce más sobre  
nuestros productos.

# BRASLUX

Daniel Rossi, 380 | Bela vista  
Caxias do Sul | RS | Brasil | 95076-100

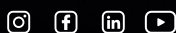
@brasluxoficial  

[braslux.com.br](http://braslux.com.br)

